

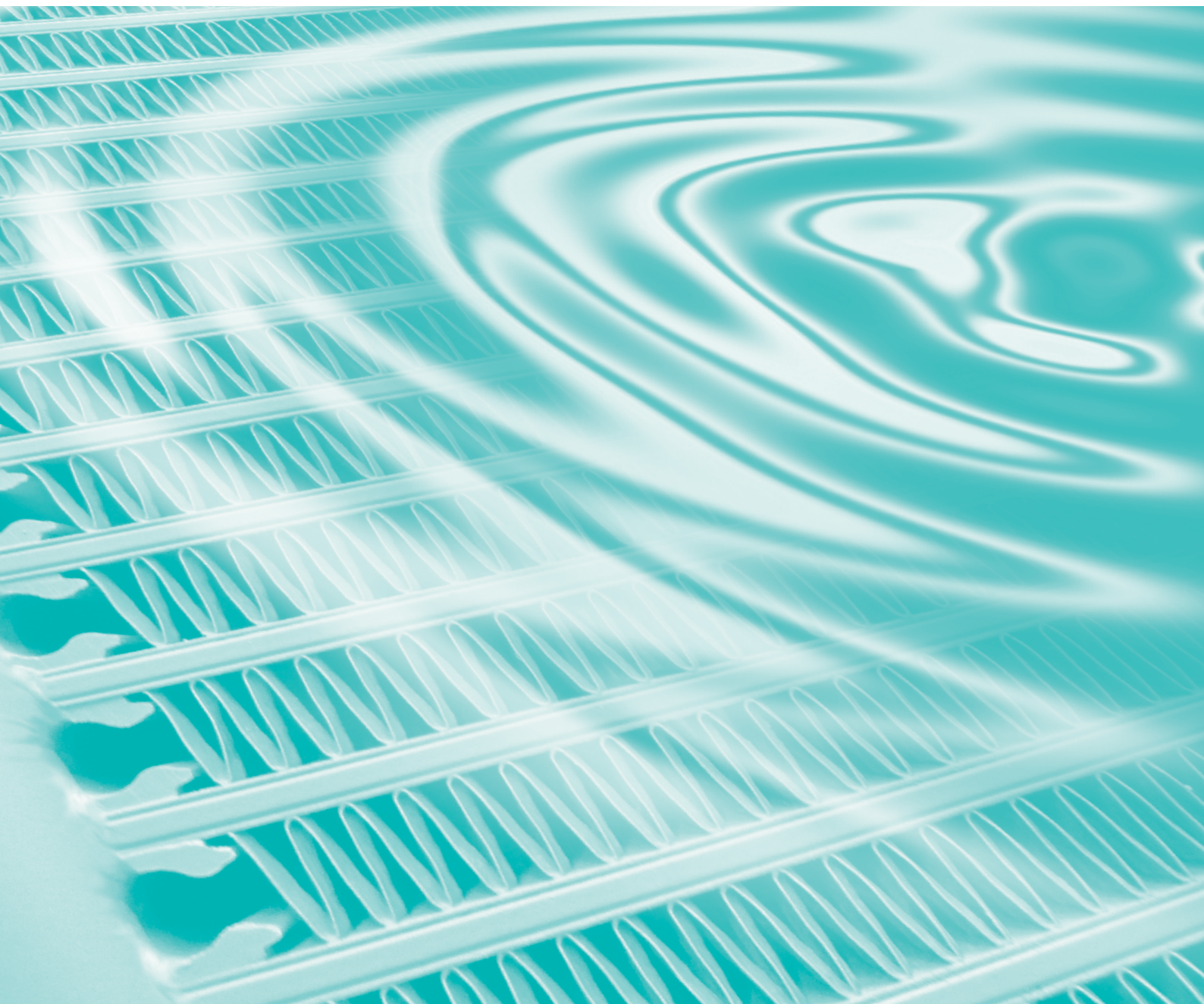

GLOBAL STANDARD COOLER
AKG-Line D



MOBILE HYDRAULIC OIL-TO-AIR COOLING SYSTEMS

PRODUCT INFORMATION

AKG-Line is a standard line of products from the market leader in high performance aluminium cooling systems. AKG is best known for its world-wide presence, German engineering and extremely reliable product quality on the one hand and very competitive prices on the other hand.

The **AKG-Line** type series consist of different models for mobile and stationary applications and are available through our global specialist dealer network. This line of products embraces all-purpose complete cooling systems that comply with European or American Standards, is suited for normal or rugged environmental operating conditions, is powered by AC-, DC- or hydraulic-motor-driven fans and is also available with noise-optimized models.

All of AKG's solutions have been developed with state-of-the-art technology, produced in compliance with the highest quality standards and are comprehensively tested in the company's own research and test facility.

FEATURES OF THE D SERIES

- High-Performance cooling assemblies
- DC motor powered fan
- The heat is transferred from the medium to be cooled to the ambient air
- Cooler can be universally used in hydraulic oil, transmission oil, engine oil, lubricating oil and coolant circuits
- For the cooling of mineral oil, synthetic oil, biological oil as well as of HFA, HFB, HFC and HFD liquids and water with at least 50 per cent of antifreeze and anticorrosive additives (other media available)
- Can be exposed to operating pressures of up to 26 bar

BENEFITS

- Largest and most comprehensive series of mobile hydraulic coolers
- Highly flexible complete, ready-to-use cooling packages
- Compact and robust design, field-tested during many years of use in rugged real life conditions

- Best heat transfer results per given cooler size due to comprehensive research and development
- Highest quality due to professional engineering and in-house manufacturing
- Available from stock or at short notice
- As a standard, equipped with **AKG's double-life** hollow sections designed to increase cooler service life
- As a standard, equipped with anti-clogging cooling air fins

FLEXIBLE AKG HOLLOW PROFILE

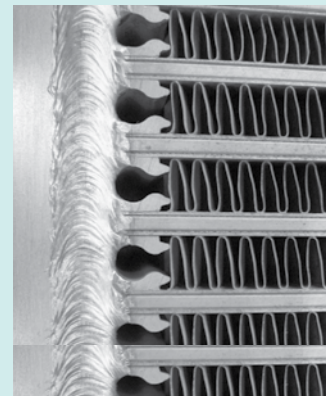

AKG-Line uses AKG hollow profiles to reduce local peak strains. This way the strength of heat exchangers is significantly increased and their service life time considerably prolonged.

AKG HOLLOW PROFILE FEATURES

- **Reduced Strain:**
Strength calculations show that when using AKG hollow profiles maximum strain is reduced by a factor of 2
- **Prolonged Service Life Time:**
Extensive rig tests have shown that service life time increases by a factor ranging from 3 to 5

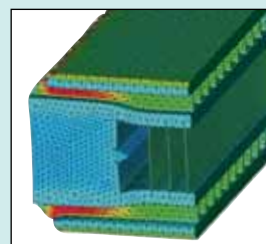

with standard profile

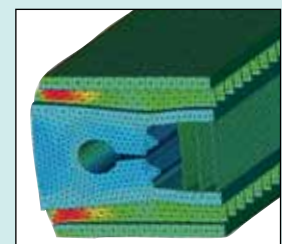

with hollow profile

EASY SIZING DIAGRAM

FOR ENTRANCE-TEMPERATURE-DIFFERENCE 40 K

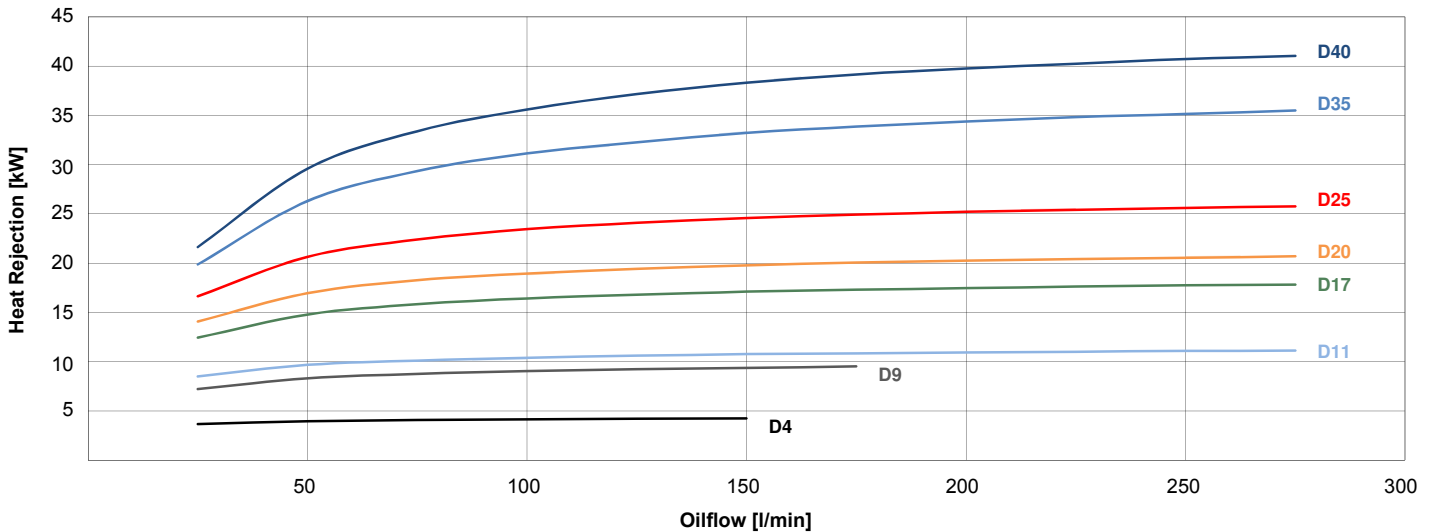

Selection by Specific Heat Rejection

1. Input Data:		
Required Heat Rejection	P =	Example 30 kW
Oilflow through Cooler	V =	150 l/min
Oil Inlet Temperature	T _{Oil}	70 °C
Cooling Airflow Temperature	T _{CAF}	30 °C
2. Determination of Specific Heat Rejection:		
Entering-Temperature-Difference	ETD =	70 °C - 30 °C = 40 K
Required Specific Heat Rejection	P/ETD	30 kW/40 K = 0,75 kW/K
3. Select According to Diagram and Result:		
		Next higher curve D 35

SPECIFIC HEAT REJECTION

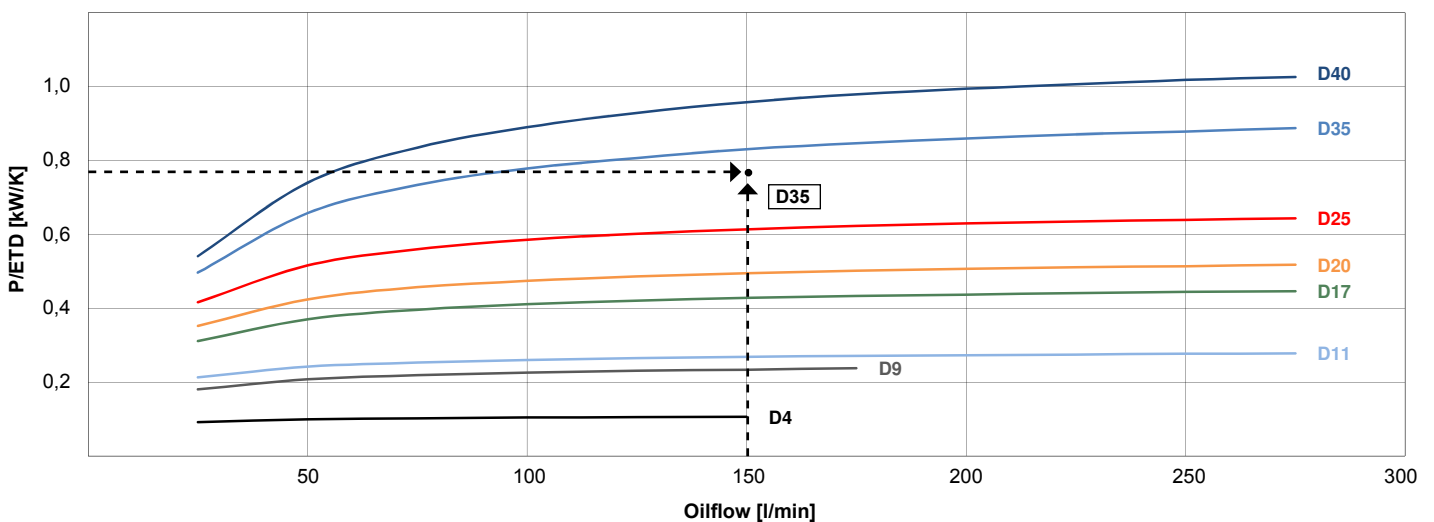

TECHNICAL DATA

Model Size	Motor Voltage (V)	Metri-Pack 630 Female Plug Data	Number of fans	Approx. Current Consumption Per Fan (A)	Approx. Noise Level (dB(A), 1m)	Approx. Net Weight Of Assembly (kg)	Volume (l)	Working Pressure (bar)
D4	12/24	Female Connector 10737825 Contact 12052456 Seal 15324994 TPA 12147060	1	8/4	80	6,4	1,4	26
D9	12/24		1	17/10	79	8,3	1,4	26
D11	12/24		1	17/10	79	10,3	1,8	26
D17	12/24		1	29/20	81	14,2	2,7	26
D20	12/24		1	29/20	81	19,5	5,1	26
D25	12/24		2	17/10	79	22,5	5,0	26
D35	12/24		2	29/20	81	24,0	4,7	26
D40	12/24		2	29/20	81	31,0	7,1	26

DIMENSIONS

Model Size	A	B	C (approx.)	D	E	F	G	H	J	K	L	M
D4	309	350	170	164	164	39	G1	315	110	160	M8	LL 11x16
D9	371	400	170	194	194	39	G1	365	110	160	M6	LL 11x16
D11	371	400	190	194	194	39	G1	365	110	160	M8	LL 11x16
D17	465	550	215	359	116	39	G1 1/4	515	110	160	M8	LL 11x16
D20	465	540	245	359	119	39	G1 1/4	510	200	250	M8	LL 11x16
D25	371	740	220	259	119	39	G1 1/4	710	200	250	M8	LL 11x16
D35	465	950	215	359	119	39	G1 1/4	915	110	160	M8	LL 11x16
D40	465	940	245	359	119	39	G1 1/4	910	200	250	M8	LL 11x16

All dimensions in mm

ORDERING INFORMATION

Serial Code: Model Size: Motor Code: Optional Custom Features:

D

-

with:

12 V [12]
24 V [24]

with Blower Fan [B]
with Resistplast Coating [+R]
PTFE Based Coating [+T]

without:

without Fan-Unit [-FM]
Cooler Only [C]
Cooler without Paint [-P]
without Support Feet [-F]

Order Code Example: Heat Exchanger, 9 KW, 12 V, sucking DC-fan -> **D9-12**
Heat Exchanger, 25 KW, 24 V, blowing DC-fan -> **D25-24B**

COOLER DIMENSIONS D4 TO D20

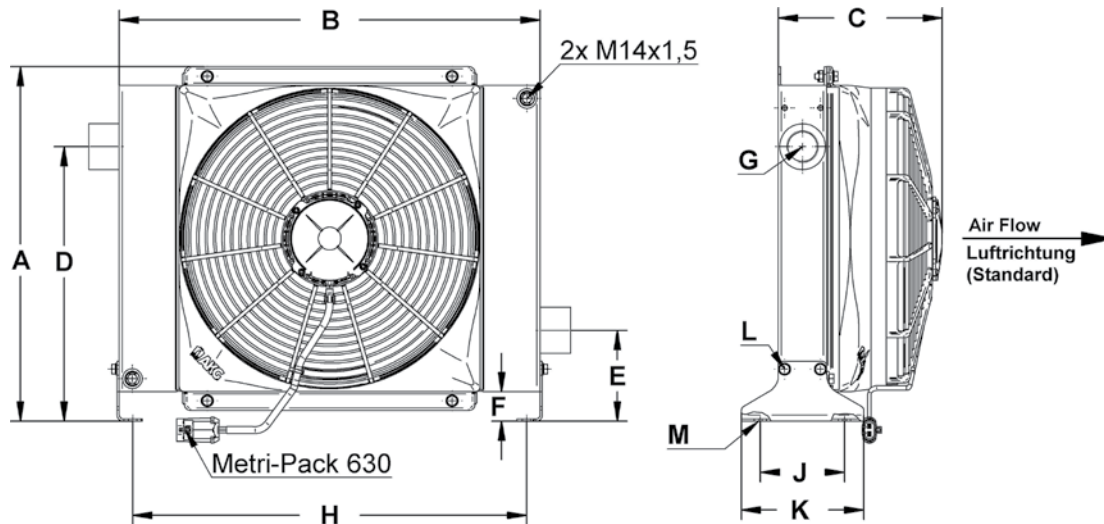

COOLER DIMENSIONS D25 TO D40

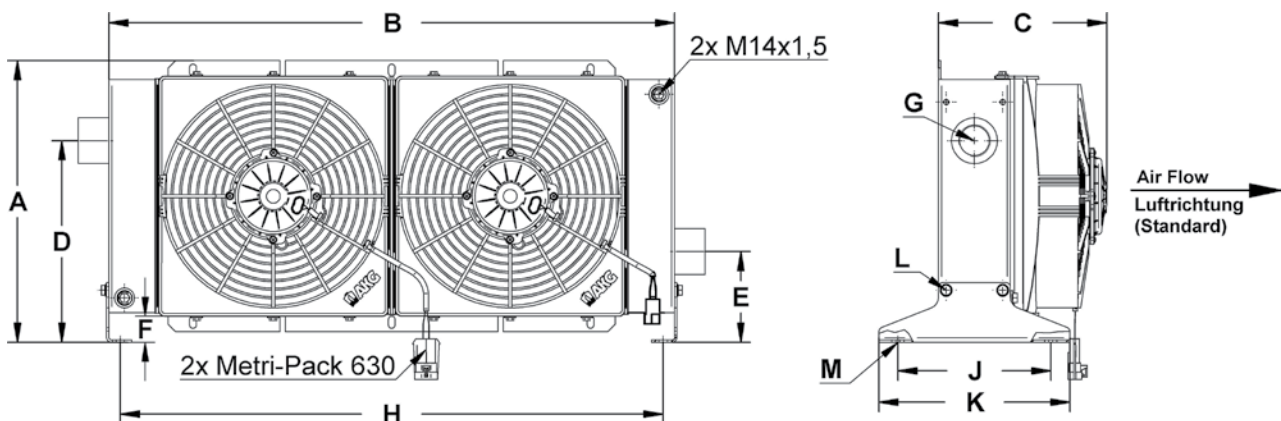

STANDARD SCOPE OF SUPPLY OF OIL-TO-AIR COOLING SYSTEM

- Cooler made of painted aluminium
- Fan unit made of plastic
- Support feed and fan-shroud (D4) all made of steel (powder coated)



AKG Thermotechnik International GmbH & Co. KG

P. O. Box 1346
34363 Hofgeismar, Germany
Tel: +49 5671 - 8 83-0
Fax: +49 5671 - 35 82
E-Mail: info@akg-group.com
Internet: www.akg-group.com

AKG – A STRONG GLOBALLY INTEGRATED GROUP OF COMPANIES

AKG is a globally leading supplier of high-performance coolers and heat exchangers as well as customised system solutions that comply with the highest quality standards.

On a world-wide scale 2,600 employees work at 13 manufacturing facilities located in Germany, France, United Kingdom, Latvia, the U.S.A., China and India. Together with a number of additional oversea sales companies they are on duty around the clock.

Your AKG-Partner

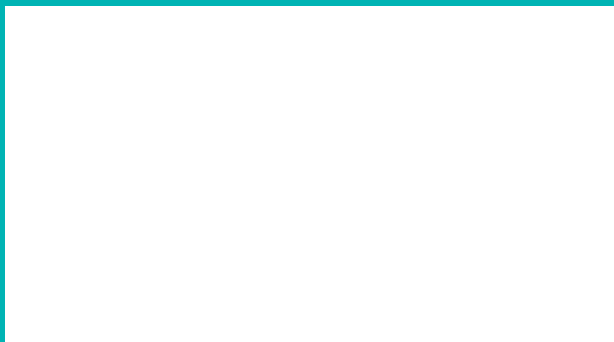

The longstanding and competent partnership with global OEM customers from 22 lines of business such as construction machinery, compressed-air systems, agricultural and forestry machines, vehicle construction and many other fields of application give fresh and innovative impetus to the mobile and industrial standard type series.

AKG operates one of the world's largest research, development, measurement and validation centres for cooling solutions and customised applications.

For 90 years AKG's heat exchangers have stood for innovative solutions as well as highest engineering and manufacturing competence.



Aluminium Coolers – Made by AKG
DIN EN ISO 9001 : 2000