

Safety Dampers



TUBUS TC and TC-S

Page 270

Crane Installations

Compact powerhouse

Crane systems, Loading and lifting equipment, Hydraulic devices, Electro-mechanical drives

TUBUS TI

Page 272

Irreversible Emergency Stop Damper

Compact one-off deceleration

Emergency stop damping in linear axes, Portal systems, Test stations, Electro-mechanical drives

Extremely durable

Highly resistant co-polyester elastomers

Lightweight designs

Cost-effective use

Heavy-duty versions available



TUBUS TC and TC-S

Compact powerhouse

Crane Installations

Energy capacity 630 Nm/Cycle to 17,810 Nm/Cycle

Maximum stroke 30 mm to 198 mm

For even more protection: The profile dampers from the TC range of the ACE TUBUS-Series can also be used as safety dampers. These maintenance-free, ready-to-install damping elements made of co-polyester elastomer have been specially developed for use in crane systems and fulfil the international industry standards OSHA and CMAA. In the special TC-S design, managed to achieve the spring rate required for crane systems with the unique dual concept.

Whether TC-S or TC, this range of models represents a cost-effective solution with high energy absorption for energy management systems. The very small and light design of Ø 64 mm to Ø 176 mm progressively covers energy absorption within a range of 450 Nm to 17,810 Nm.

The profile dampers from the TC range protect cranes, loading and lifting equipment, hydraulic units and much more.



Technical Data

Energy capacity: 630 Nm/Cycle to 17,810 Nm/Cycle

Energy absorption: 31 % to 64 %

Dynamic force range: 80,000 N to 978,000 N

Operating temperature range: -40 °C to +90 °C

Construction size: 64 mm to 176 mm

Material hardness rating: Shore 55D

Material: Profile body: Co-Polyester Elastomer

Mounting: In any position

Environment: Resistant to microbes, seawater or chemical attack. Excellent UV and ozone resistance. Material does not absorb water or swell.

Impact velocity range: Max. 5 m/s

Torque max.:

M12: 50 Nm

M16: 40 Nm (DIN912)

M16: 120 Nm (shouldered screw)

Application field: Crane systems, Loading and lifting equipment, Hydraulic devices, Electro-mechanical drives

Note: Suitable for emergency stop applications and for continuous use. For applications with preloading and increased temperatures please consult ACE.

On request: Special strokes, -characteristics, -spring rates, -sizes and -materials.

TC

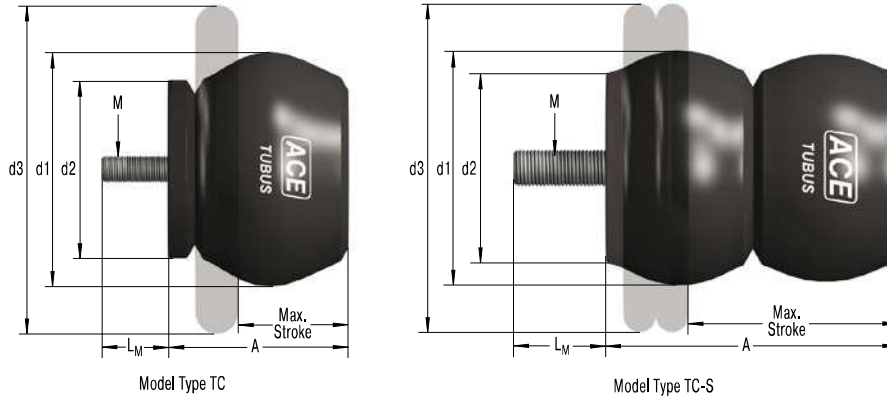

Characteristics

Type TC90-49
Energy-Stroke Characteristic (dynamic)
(with impact velocity over 0.5 m/s)

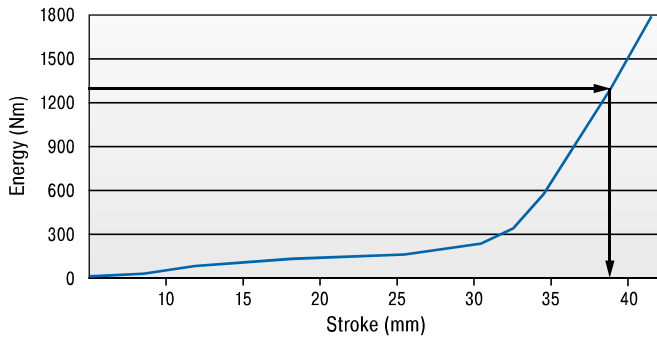

Type TC90-49
Force-Stroke Characteristic (dynamic)
(with impact velocity over 0.5 m/s)

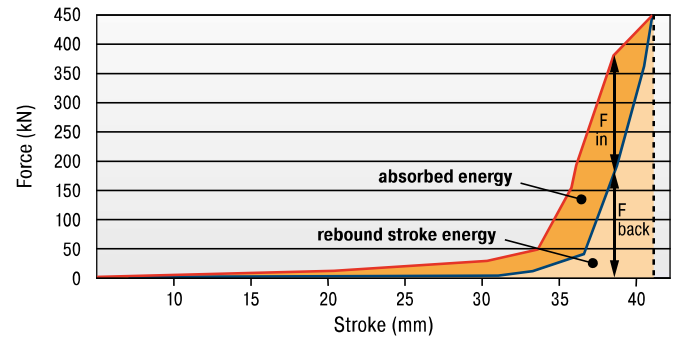

With the aid of the characteristic curves above you can estimate the proportion of the total energy that will be absorbed.

Example: With impact energy of 1,300 Nm the Energy-Stroke diagram shows that a stroke of about 38 mm is needed.

On the Force-Stroke diagram you can estimate the proportion of absorbed energy to rebound energy at this stroke length.

Note: With these types the return force towards the end of the stroke is significant and we recommend you try to use a minimum of 90 % of the total stroke available.

Dynamic ($v > 0.5$ m/s) and static ($v \leq 0.5$ m/s) characteristics of all types are available on request.

The calculation and selection of the most suitable damper should be carried out or be approved by ACE.

Ordering Example

TUBUS Crane Buffer _____ **TC83-73-S**
 Outer-Ø 83 mm _____
 Stroke 73 mm _____
 Model Type Soft _____

Performance and Dimensions

TYPES	Emergency Stop		Stroke max. mm	A mm	d1 mm	d2 mm	d3 mm	L _M mm	M	Weight kg
	¹ W ₃ Nm/cycle	W ₃ Nm/cycle								
TC64-62-S	450	630	62	79	64	52	89	12	M12	0.174
TC74-76-S	980	1,372	76	96	74	61	114	12	M12	0.260
TC83-73-S	1,940	2,715	73	94	83	69	127	12	M12	0.328
TC86-39	1,210	1,695	39	56	86	78	133	12	M12	0.284
TC90-49	1,640	2,295	49	68	90	67	124	12	M12	0.264
TC100-59	1,785	2,500	59	84	100	91	149	12	M12	0.452
TC102-63	1,970	2,760	63	98	102	82	140	22	M16	0.662
TC108-30	1,900	2,660	30	53	108	77	133	12	M12	0.392
TC117-97	3,710	5,195	97	129	117	100	188	16	M16	1.043
TC134-146-S	7,310	10,230	146	188	134	117	215	30	M16	1.573
TC136-65	4,250	5,950	65	106	136	106	178	16	M16	1.147
TC137-90	6,350	8,890	90	115	137	113	216	21	M16	1.201
TC146-67-S	8,330	11,660	67	118	146	99	191	16	M16	1.573
TC150-178-S	8,860	12,400	178	241	150	132	224	16	M16	2.674
TC153-178-S	7,260	10,165	178	226	153	131	241	16	M16	2.522
TC168-124	10,100	14,140	124	166	168	147	260	16	M16	2.533
TC176-198-S	12,725	17,810	198	252	176	150	279	16	M16	3.685

¹ Max. energy capacity per cycle for continuous use.

TUBUS TI

Compact one-off deceleration

Irreversible Emergency Stop Damper

Energy capacity 562 Nm/Cycle to 10,953 Nm/Cycle

Maximum stroke 25 mm to 80 mm

Once only, but safely: ACE now offers these innovative single use TUBUS TI absorbers for emergency stop applications as an alternative to the successful TUBUS profile dampers. In comparison to standard elastomer absorbers, these safety dampers ensure energy absorption of up to 96 % without a recoil effect. The dampers are deformed in the impact and cannot be reused afterwards.

The easy to assemble and maintenance-free single hit damper are also a cost-effective alternative to the hydraulic safety shock absorbers from ACE. They are made of a high quality synthetic with an inside metal core and absorb up to 10,953 Nm energy.

The TUBUS TI is mainly used as emergency stop damping in linear axes, tool machines, servo drives with high speeds and other similar areas.

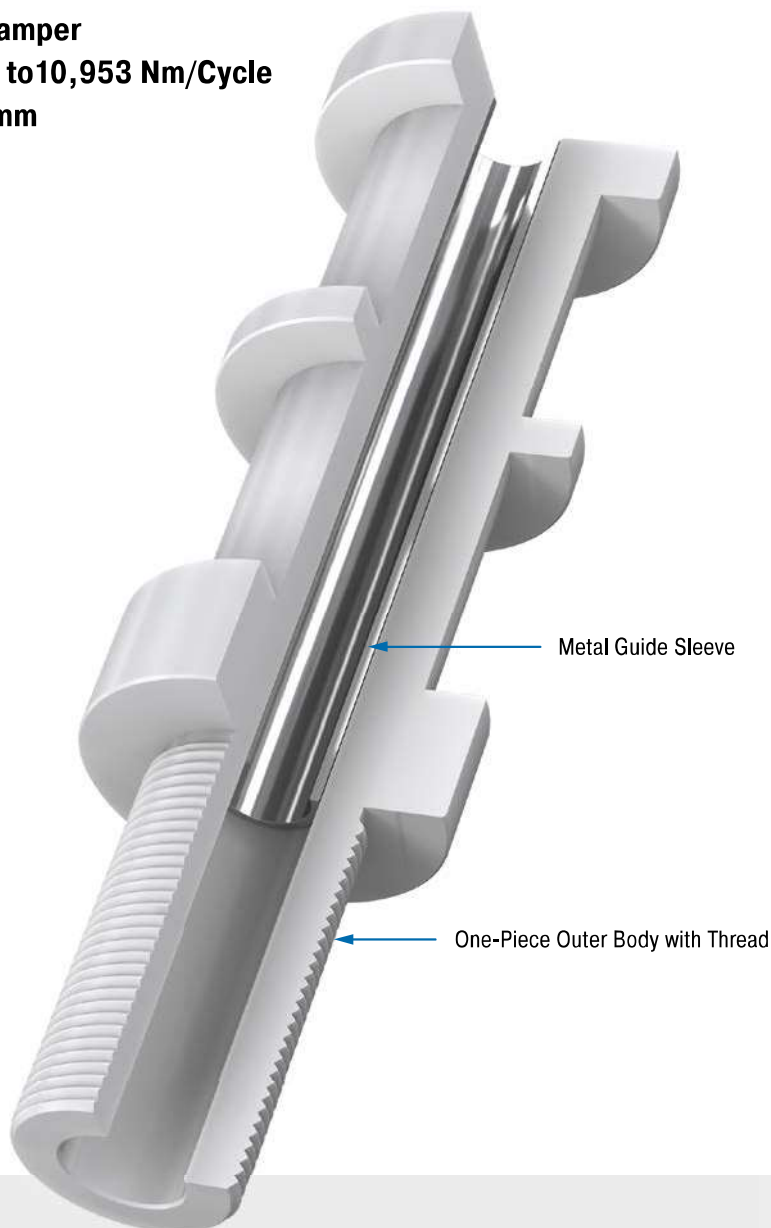

Technical Data

Energy capacity: 562 Nm/Cycle to 10,953 Nm/Cycle

Energy absorption: 91 % to 96 %

Dynamic force range: 37,138 N to 204,127 N

Operating temperature range:

-40 °C to +90 °C, Co-polyester Elastomer

-25 °C to +50 °C, Polymer

Construction size: 32 mm to 63 mm

Material: Profile body: Co-Polyester elastomer or polymer; Guide sleeve: Metal

Mounting: In any position

Environment: Resistant to lubricants and chemical attack according to resistance list. No UV resistance.

Impact velocity range: Max. 5 m/s

Torque max.: Finger tight

Application field: Emergency stop damping in linear axes, Portal systems, Test stations, Electro-mechanical drives

Note: The single-use damper must be replaced after each impact.

On request: Other construction sizes on request.

TI16

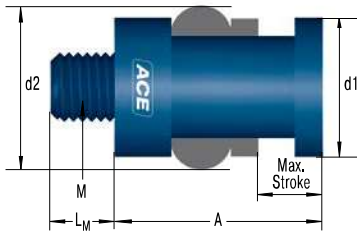

TI24

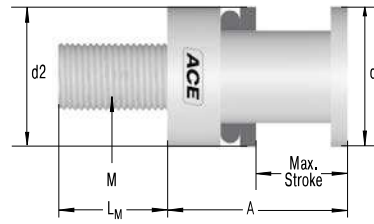

TI30

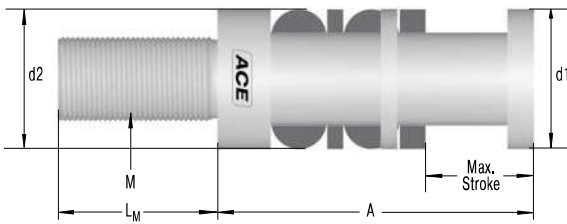

TI36

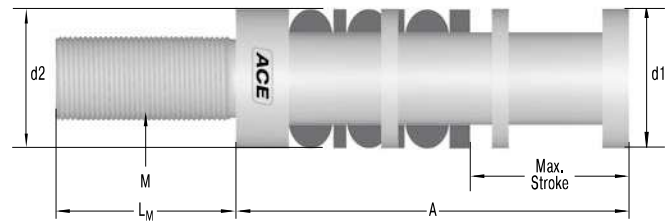

Characteristics

Force-Stroke TI16

Dynamic trials on a drop test rig

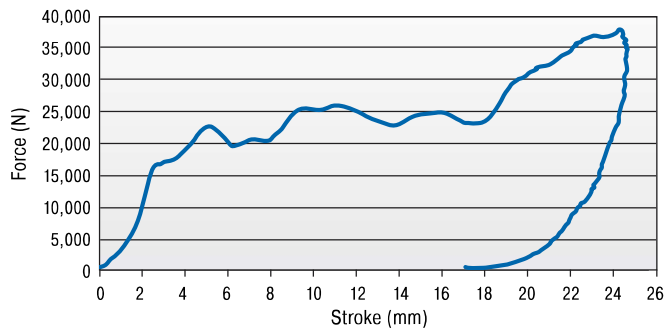

	TI16
Total energy:	562 Nm
Absorbed energy:	511 Nm
Efficiency:	91 %

Force-Stroke TI24, TI30 and TI36

Dynamic trials on a drop test rig

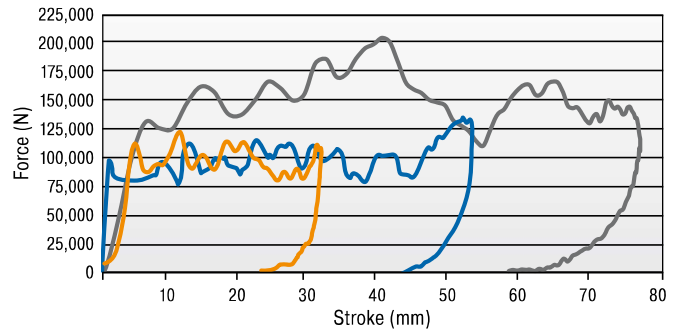

	TI36	TI30	TI24
Total energy:	10,954 Nm	4,510 Nm	2,701 Nm
Absorbed energy:	10,513 Nm	4,309 Nm	2,545 Nm
Efficiency:	96 %	96 %	94 %

The characteristic values have been established under dynamic load.

The calculation and selection of the most suitable damper should be carried out or be approved by ACE.

Ordering Example

TUBUS Irreversible _____ ↑
 Thread Size M16 _____ ↑
 Stroke 25 mm _____ ↑
 Number of Bellows _____ ↑

TI16-25-1

Performance and Dimensions

TYPES	Energy capacity emergency use Nm/cycle	Stroke max. mm	Reacting Force N	A mm	d1 mm	d2 mm	L _M mm	M	Depth thread hole min. mm	Weight kg
TI16-25-1	562	25	37,138	48	32	38	15	M16x2	25	0.045
TI24-33-1	2,701	33	113,590	64.5	50	50	40	M24x3	40	0.140
TI30-52-2	4,510	52	121,130	113	50	50	57	M30x3.5	63	0.240
TI36-80-3	10,953	80	204,127	172	63	65	89	M36x4	89	0.620