

**DIRECTIONAL CONTROL VALVES  
INSERT-TYPE CARTRIDGE CHECK VALVES**

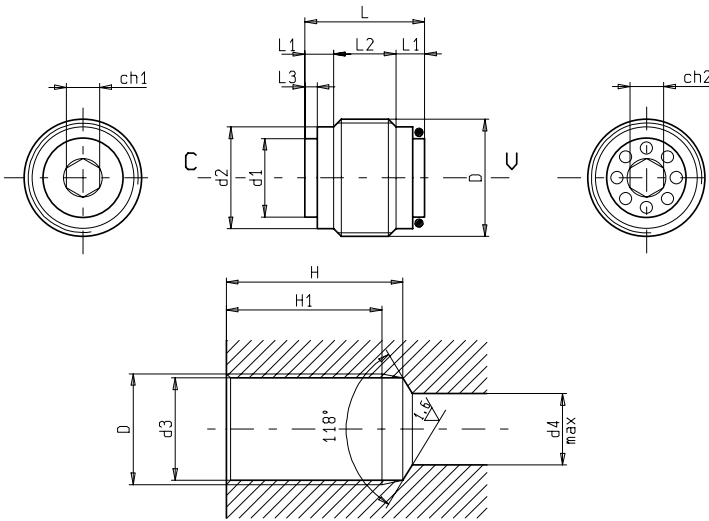

**VU-LN**

**OD.44.02.00 - Y - Z**



**DESCRIPTION - OPERATION**

These valves are particularly suitable to be used in integrated circuits due to very small dimensions and ease of installation. They have to be mounted as indicated .

**FEATURES - RATINGS**

**Maximum Operating Pressure 350 bar**

**Rated Flow see table**

- Fluids - Temperatures - Testing Conditions - Seals : see page 7.01.04
- Internal Leakage : see page 7.01.04
- Filtration : 25 µm nominal or better, see page 7.01.05



L3	L2	L1	L	H1	H	ch2	ch1	d4	d3	d2	d1	Y
1	6	5.5	17	25	28	3	3	8	11.8	11.3	9.2	09
1.8	7.5	5.5	18.5	27	30	3	4	9	15.2	14.8	11	02
1.8	9.5	6.5	22.5	32	36	5	6	12	19	18.5	14.2	03
2.7	14.5	7	28.5	37	42	8	8	17	24.5	24.1	19	04

Z	CRACKING PRESSURE bar			
	G 1/4	G 3/8	G 1/2	G 3/4
01	2.3	1.75	1.75	0.3

O - Ring Size	O - Ring Code	TIGHTENING TORQUE Cartridge	WEIGHT Kg	FLOW MAX. l/min	D	Y
9 x 1	11.02.01.989	6 Nm	0.015	15	G 1/4	09
10.8 x 1.8	11.02.01.015	6 Nm	0.025	30	G 3/8	02
14 x 1.8	11.02.01.018	10 Nm	0.040	50	G 1/2	03
18.7 x 2.6	11.02.01.072	20 Nm	0.070	80	G 3/4	04

PRESSURE DROP

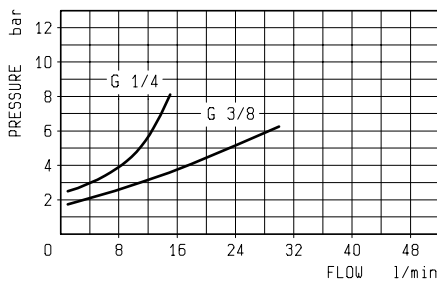

PRESSURE DROP

