

Manifolds

RE 18325-85/02.10 1/16
Replaces: RE 00199/11.07

Standard manifolds common cavity
 Standard manifolds special cavity
 Manifolds with emergency screw



Summary

Description	Page
Standard manifold common cavity aluminium or steel	
Size 08	2-3
Size 10	4-5
Size 12	6-7
Size 16	8-9
Size 20	10-11
Standard manifold special cavity aluminium or steel	
017-E	12
021-E	12
019-E	12
004	13
Manifold with emergency screw aluminium or steel	
Size 08	14
017-E	14
021-E	14

General specifications

- Max operating pressure for steel body: **350 bar (5000 psi)**
- Max operating pressure for aluminium body: **210 bar (3000 psi)**

Note: aluminium bodies are often strong enough for operating pressures exceeding 210 bar (3000 psi), depending from the fatigue life expected in the specific application. If in doubt, consult our Service Network.

Standard manifolds - Common cavity Size 08 - Aluminium / Steel

CAVITY: CA-08A-2N

	Ordering code	Ports 1-2	Weight kg (lbs)
Aluminium	OC1009009 R901090786	G 1/4	0.17 (0.38)
	OC1009004 R901082022	G 3/8	0.16 (0.35)
Steel	OC1009067 R901090800	G 1/4	0.47 (1.04)
	OC1009066 R901090799	G 3/8	0.45 (0.99)

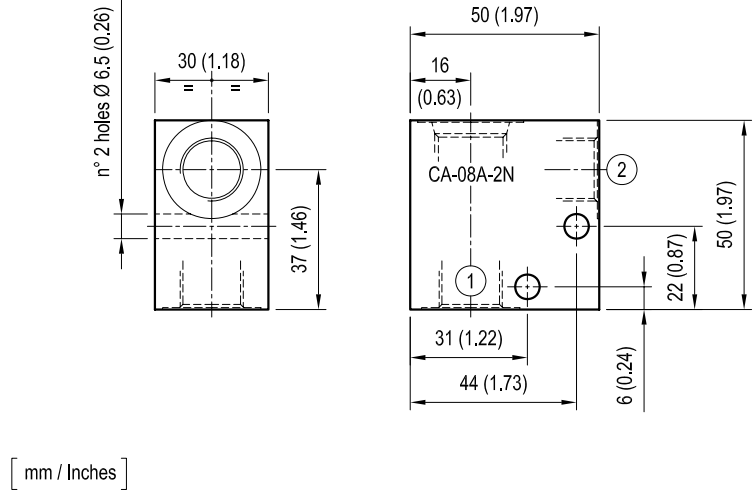

[mm / Inches]

CAVITY: CA-08A-3C

	Ordering code	Ports 1-2 3	Weight kg (lbs)
Aluminium	OC1009262 R934000223	G 1/4 G 1/4	0.25 (0.55)
	OC1009260 R934000221	G 3/8 G 1/4	0.25 (0.55)
Steel	OC1009263 R934000224	G 1/4 G 1/4	0.71 (1.57)
	OC1009261 R934000222	G 3/8 G 1/4	0.69 (1.52)

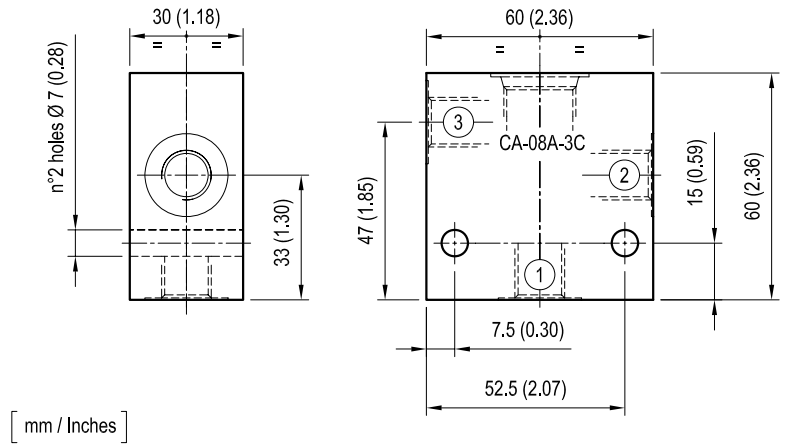

[mm / Inches]

CAVITY: CA-08A-3C
(DOUBLE CAVITY)

	Ordering code	Ports V1-V2-C1-C2	Weight kg (lbs)
Aluminium	OC1009185 R934000146	G 3/8	0.36 (0.79)
Steel	OC1009184 R934000145	G 3/8	1.00 (2.21)

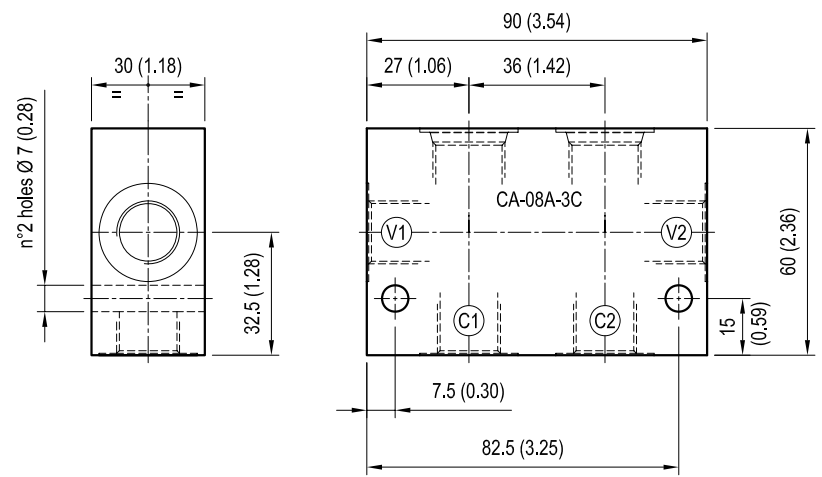

[mm / Inches]

Standard manifolds - Common cavity Size 08 - Aluminium / Steel

CAVITY: CA-08A-3N

	Ordering code	Ports 1-2-3	Weight kg (lbs)
Aluminium	OC1009042 R901100471	G 1/4	0.30 (0.66)
	OC1009048 R901100497	G 3/8	0.27 (0.60)
Steel	OC1009225 R934000186	G 1/4	0.78 (1.72)
	OC1009153 R934000140	G 3/8	0.74 (1.63)

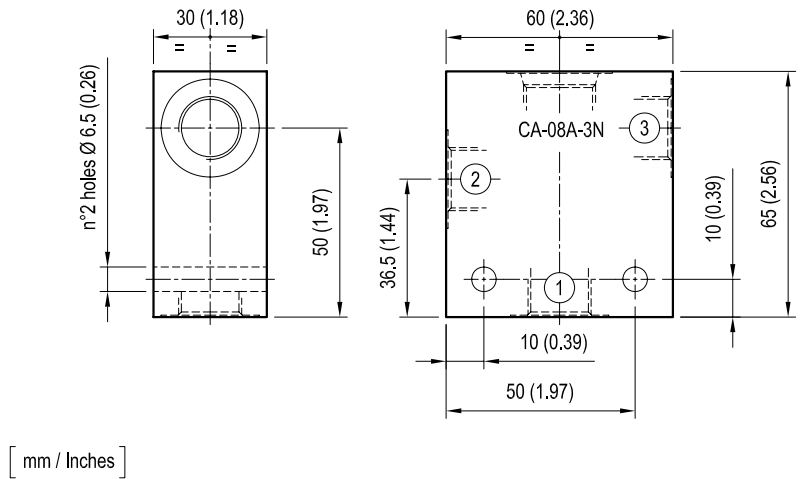

[mm / Inches]

CAVITY: CA-08A-4N

	Ordering code	Ports 1-2-3-4	Weight kg (lbs)
Aluminium	OC1009047 R901100531	G 1/4	0.33 (0.73)
	OC1009046 R901100524	G 3/8	0.29 (0.64)
Steel	OC1009236 R934000197	G 1/4	0.93 (2.05)
	OC1009237 R934000198	G 3/8	0.81 (1.79)

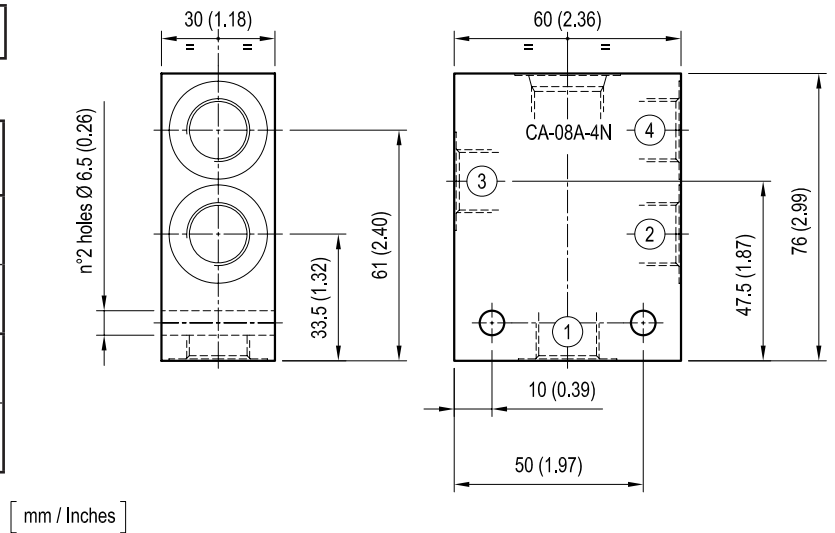

[mm / Inches]

Standard manifolds - Common cavity Size 10 - Aluminium / Steel

CAVITY: CA-10A-2N

	Ordering code	Ports 1-2	Weight kg (lbs)
Aluminium	OC1009209 R934000170	G 1/2	0.28 (0.62)
	OC1009211 R934000172	G 3/4	0.36 (0.79)
Steel	OC1009210 R934000171	G 1/2	0.77 (1.70)
	OC1009212 R934000173	G 3/4	1.00 (2.21)

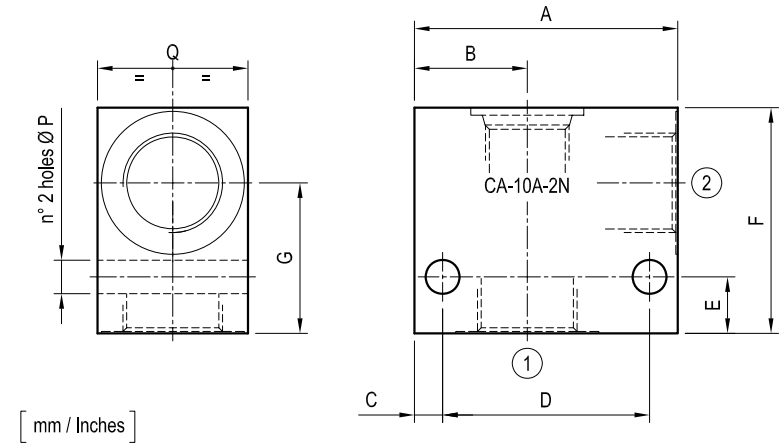

[mm / Inches]

60 (2.36)	25 (0.98)	7.50 (0.30)	45 (1.77)	15 (0.59)	60 (2.36)	41 (1.61)	-	-	-	-	-	-	-	7 (0.28)	35 (1.38)	-	-	-	G 1/2
70 (2.76)	30 (1.18)	7.5 (0.30)	55 (2.17)	15 (0.59)	60 (2.36)	40 (1.57)	-	-	-	-	-	-	-	9 (0.35)	40 (1.58)	-	-	-	G 3/4
A	B	C	D	E	F	G	H	I	L	M	N	O	P	Q	R	S	PORTS		

CAVITY: CA-10A-3C

	Ordering code	Ports 1-2	3	Weight kg (lbs)
Aluminium	OC1009264 R934000225	G 3/8	G 1/4	0.34 (0.75)
	OC1009266 R934000227	G 1/2	G 1/4	0.39 (0.86)
Steel	OC1009265 R934000226	G 3/8	G 1/4	0.94 (2.07)
	OC1009267 R934000228	G 1/2	G 1/4	1.10 (2.43)

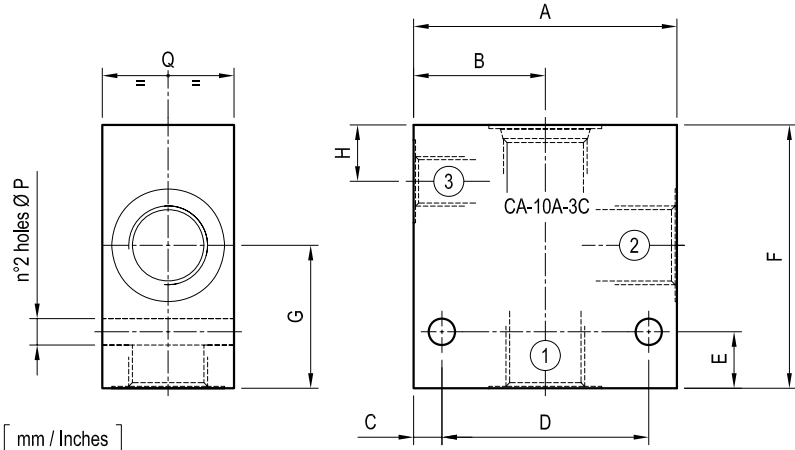

[mm / Inches]

60 (2.36)	30 (1.18)	7.5 (0.30)	45 (1.77)	15 (0.59)	70 (2.76)	38 (1.50)	15 (0.59)	-	-	-	-	-	-	7 (0.28)	35 (1.38)	-	-	-	G 3/8
70 (2.76)	35 (1.38)	7.5 (0.30)	55 (2.17)	15 (0.59)	70 (2.76)	38 (1.50)	15 (0.59)	-	-	-	-	-	-	7 (0.28)	35 (1.38)	-	-	-	G 1/2
A	B	C	D	E	F	G	H	I	L	M	N	O	P	Q	R	S	PORTS		

**CAVITY: CA-10A-3C
(DOUBLE CAVITY)**

	Ordering code	Ports V1-V2-C1-C2	Weight kg (lbs)
Aluminium	OC1009187 R934000148	G 3/8	0.75 (1.65)
	OC1009189 R934000150	G 1/2	0.72 (1.59)
Steel	OC1009186 R934000147	G 3/8	2.10 (4.63)
	OC1009188 R934000149	G 1/2	2.03 (4.48)

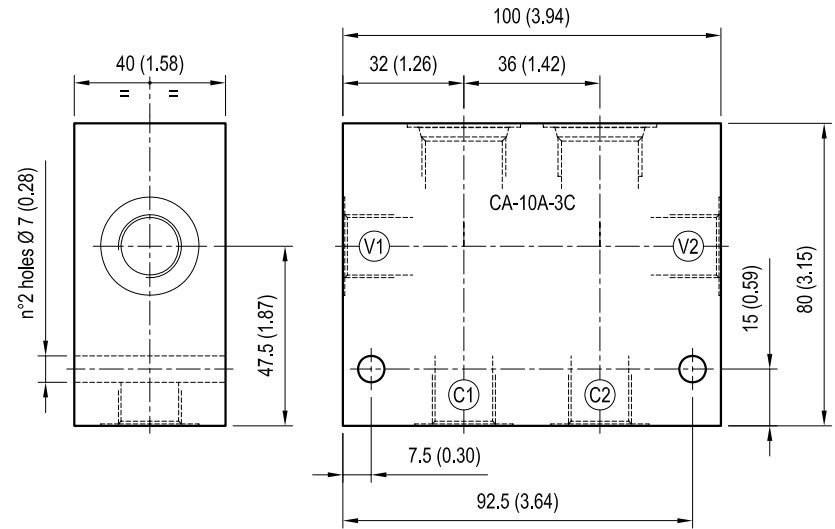

[mm / Inches]

Standard manifolds - Common cavity Size 10 - Aluminium / Steel

CAVITY: CA-10A-3N

	Ordering code	Ports 1-2-3	Weight kg (lbs)
Aluminium	OC1009116 R901100626	G 1/4	0.35 (0.77)
	OC1009115 R901100638	G 3/8	0.34 (0.75)
	OC1009283 R934000244	G 1/2	0.38 (0.84)
Steel	OC1009226 R934000187	G 1/4	0.98 (2.16)
	OC1009227 R934000188	G 3/8	0.95 (2.09)
	OC1009284 R934000245	G 1/2	1.07 (2.36)

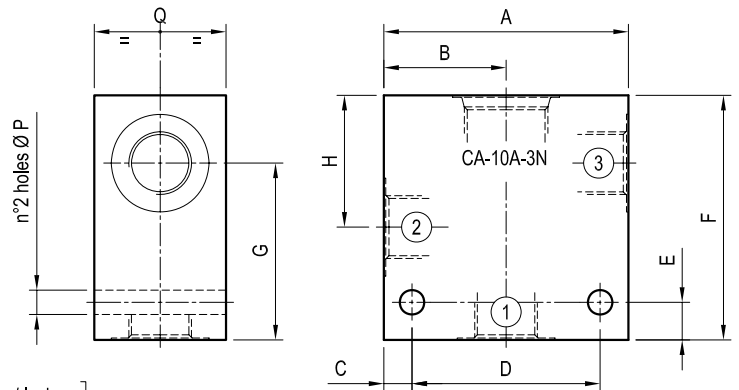

[mm / Inches]

65 (2.56)	32.5 (1.28)	7.5 (0.30)	50 (1.97)	10 (0.39)	65 (2.56)	47 (1.85)	35 (1.38)	-	-	-	-	-	-	6.5 (0.26)	35 (1.38)	-	-	G 1/4
65 (2.56)	32.5 (1.28)	7.5 (0.30)	50 (1.97)	10 (0.39)	65 (2.56)	47 (1.85)	35 (1.38)	-	-	-	-	-	-	6.5 (0.26)	35 (1.38)	-	-	G 3/8
70 (2.76)	35 (1.38)	10 (0.39)	50 (1.97)	15 (0.59)	70 (2.76)	52 (2.05)	35 (1.38)	-	-	-	-	-	-	6.5 (0.26)	35 (1.38)	-	-	G 1/2
A	B	C	D	E	F	G	H	I	L	M	N	O	P	Q	R	S	PORTS	

CAVITY: CA-10A-4N

	Ordering code	Ports 1-2-3-4	Weight kg (lbs)
Aluminium	OC1009117 R901100734	G 1/4	0.43 (0.95)
	OC1009118 R901100747	G 3/8	0.41 (0.90)
Steel	OC1009238 R934000199	G 1/4	1.21 (2.67)
	OC1009239 R934000200	G 3/8	1.15 (2.54)

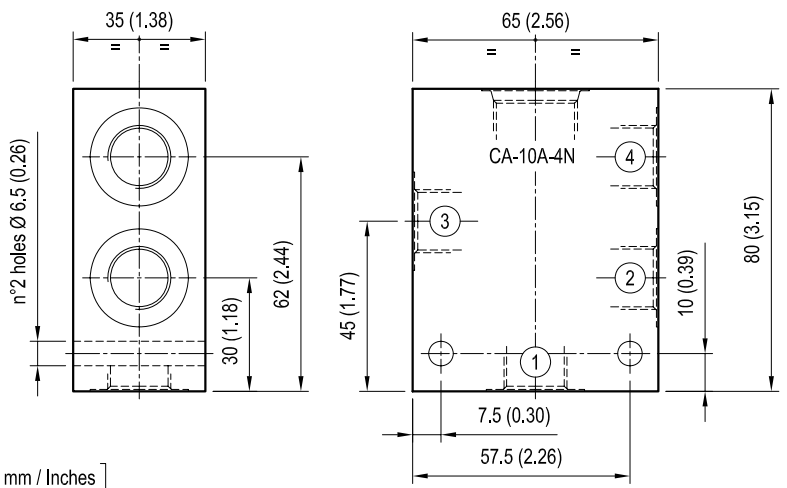

[mm / Inches]

CAVITY: CA-10A-4N
(Port 1 closed)

	Ordering code	Ports 1-2-3-4	Weight kg (lbs)
Aluminium	OC1009252 R934000213	G 3/8	0.42 (0.93)
	OC1009254 R934000215	G 1/2	0.40 (0.88)
Steel	OC1009253 R934000214	G 3/8	1.18 (2.60)
	OC1009255 R934000216	G 1/2	1.12 (2.47)

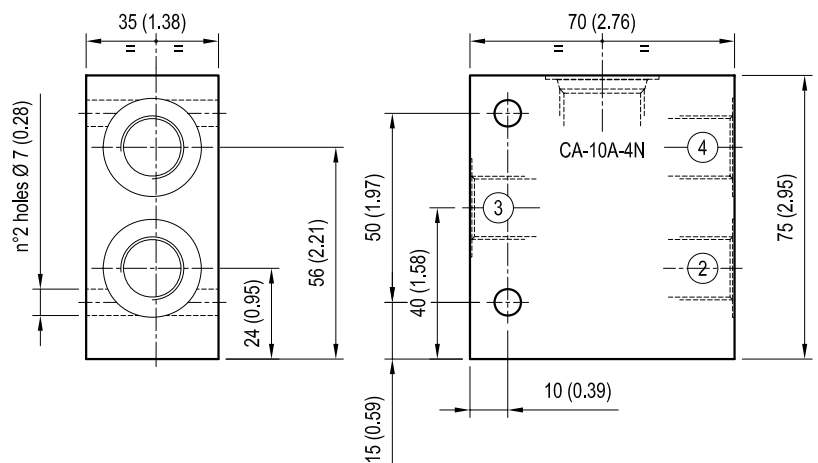

[mm / Inches]

Standard manifolds - Common cavity Size 12 - Aluminium / Steel

CAVITY: CA-12A-2N

	Ordering code	Ports 1-2	Weight kg (lbs)
Aluminium	OC1009213 R934000174	G 3/4	0.52 (1.15)
	OC1009215 R934000176	G 1	0.64 (1.41)
Steel	OC1009214 R934000175	G 3/4	1.46 (3.22)
	OC1009216 R934000177	G 1	1.79 (3.95)

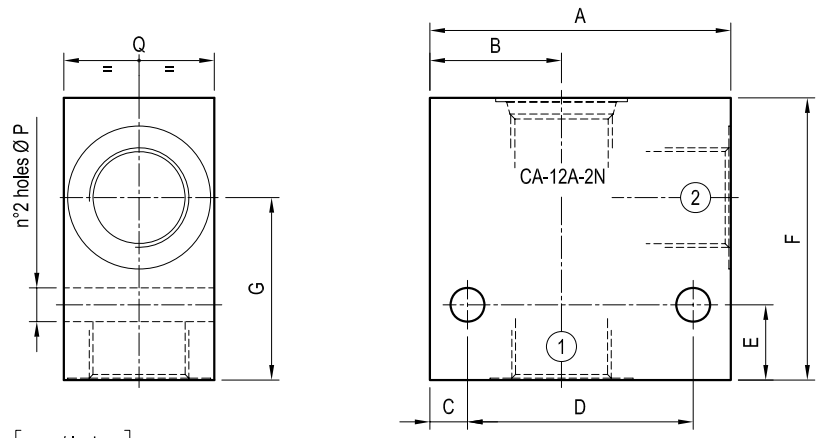

[mm / Inches]

80 (3.15)	35 (1.38)	10 (0.39)	60 (2.36)	20 (0.79)	75 (2.95)	48.5 (1.91)	-	-	-	-	-	-	-	9 (0.35)	40 (1.58)	-	-	G 3/4
80 (3.15)	35 (1.38)	10 (0.39)	60 (2.36)	20 (0.79)	75 (2.95)	48.5 (1.91)	-	-	-	-	-	-	-	9 (0.35)	50 (1.97)	-	-	G 1
A	B	C	D	E	F	G	H	I	L	M	N	O	P	Q	R	S	PORTS	

CAVITY: CA-12A-3C

	Ordering code	Ports 1-2	3	Weight kg (lbs)
Aluminium	OC1009268 R934000229	G 1/2	G 1/4	0.54 (1.19)
	OC1009270 R934000231	G 3/4	G 1/4	0.59 (1.30)
Steel	OC1009269 R934000230	G 1/2	G 1/4	1.51 (3.33)
	OC1009271 R934000232	G 3/4	G 1/4	1.65 (3.64)

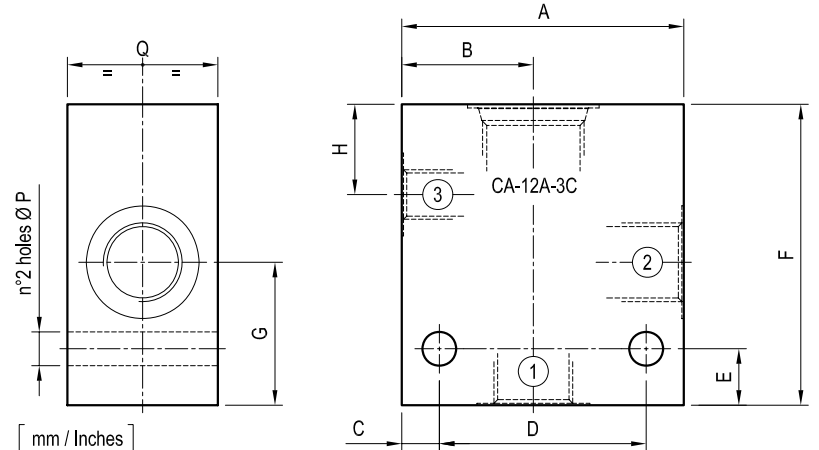

[mm / Inches]

75 (2.95)	35 (1.38)	10 (0.39)	55 (2.17)	15 (0.59)	80 (3.15)	38 (1.50)	24 (0.95)	-	-	-	-	-	-	9 (0.35)	40 (1.58)	-	-	G 1/2
75 (2.95)	35 (1.38)	10 (0.39)	55 (2.17)	15 (0.59)	90 (3.54)	48 (1.89)	24 (0.95)	-	-	-	-	-	-	9 (0.35)	40 (1.58)	-	-	G 3/4
A	B	C	D	E	F	G	H	I	L	M	N	O	P	Q	R	S	PORTS	

CAVITY: CA-12A-3C (DOUBLE CAVITY)

	Ordering code	Ports V1-V2-C1-C2	Weight kg (lbs)
Aluminium	OC1009191 R934000152	G 1/2	1.31 (2.89)
	OC1009193 R934000154	G 3/4	1.26 (2.78)
Steel	OC1009190 R934000151	G 1/2	3.69 (8.14)
	OC1009192 R934000153	G 3/4	3.54 (7.80)

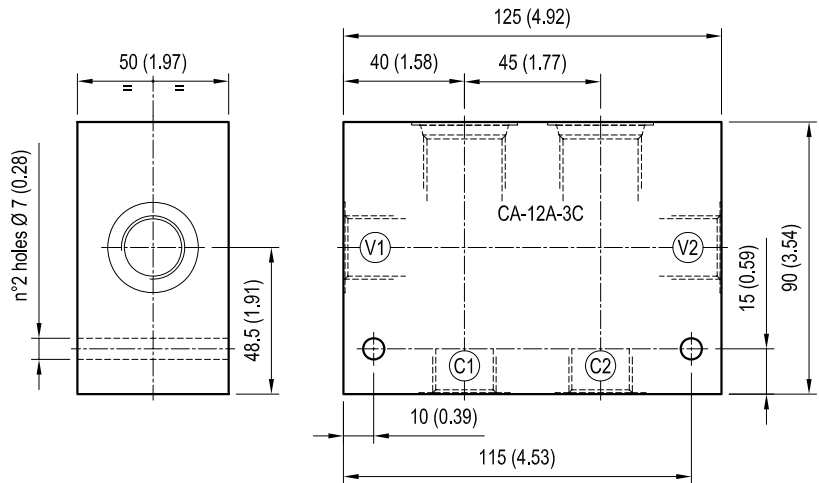

[mm / Inches]

Standard manifolds - Common cavity Size 12 - Aluminium / Steel

CAVITY: CA-12A-3N

	Ordering code	Ports 1-2-3	Weight kg (lbs)
Aluminium	OC1009205 R934000166	G 1/2	0.73 (1.61)
	OC1009208 R934000169	G 3/4	0.69(1.52)
Steel	OC1009206 R934000167	G 1/2	2.04 (4.50)
	OC1009207 R934000168	G 3/4	1.93 (4.26)

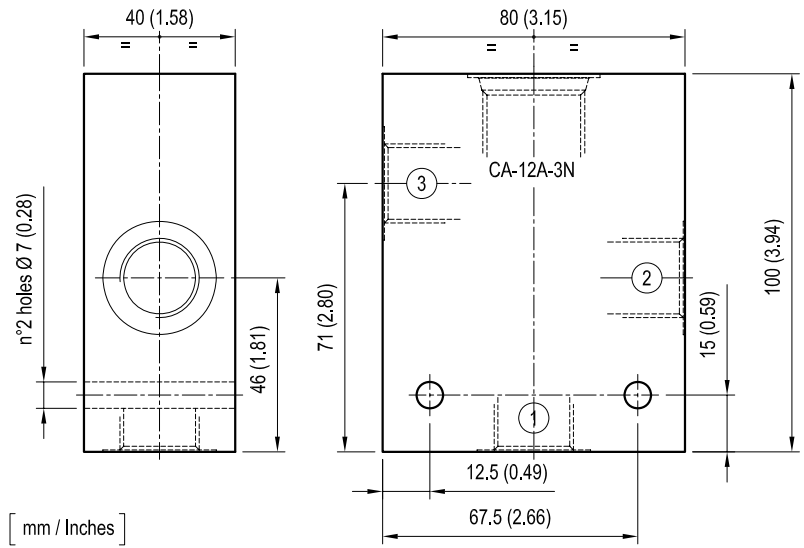

[mm / Inches]

CAVITY: CA-12A-4N

	Ordering code	Ports 1-2-3-4	Weight kg (lbs)
Aluminium	OC1009240 R934000201	G 3/4	0.85 (1.87)
	OC1009242 R934000203	G 1	1.26 (2.78)
Steel	OC1009241 R934000202	G 3/4	2.40 (5.29)
	OC1009243 R934000204	G 1	3.53 (7.78)

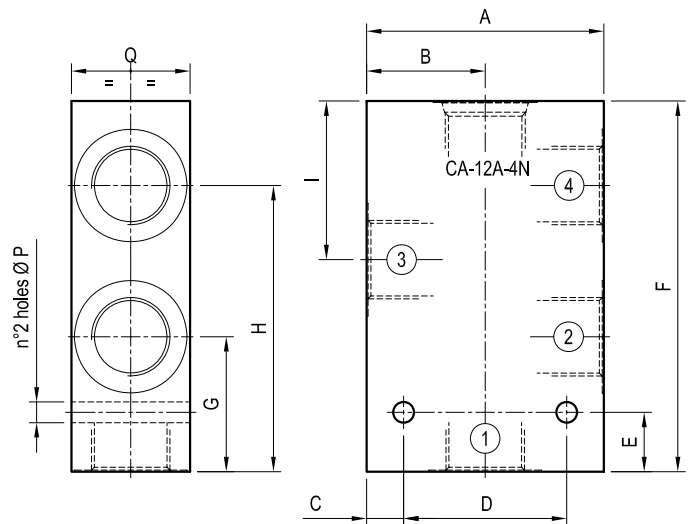

[mm / Inches]

80	40	12.5	55	20	125	45.5	96.5	53.5	-	-	-	-	7	40	-	-	G 3/4
(3.15)	(1.58)	(0.49)	(2.17)	(0.79)	(4.92)	(1.79)	(3.80)	(2.11)	-	-	-	-	(0.28)	(1.58)	-	-	
90	45	17.5	55	20	130	50.5	101.5	53.5	-	-	-	-	7	50	-	-	G 1
(3.54)	(1.77)	(0.69)	(2.17)	(0.79)	(5.12)	(1.99)	(3.40)	(2.11)	-	-	-	-	(0.28)	(1.97)	-	-	
A	B	C	D	E	F	G	H	I	L	M	N	O	P	Q	R	S	PORTS

Standard manifolds - Common cavity

Size 16 - Aluminium / Steel

CAVITY: CA-16A-2N

	Ordering code	Ports 1-2	Weight kg (lbs)
Aluminium	OC1009217 R934000178	G 3/4	0.69 (1.52)
	OC1009219 R934000180	G 1	0.75 (1.65)
Steel	OC1009218 R934000179	G 3/4	1.94 (4.28)
	OC1009220 R934000181	G 1	2.11 (4.65)

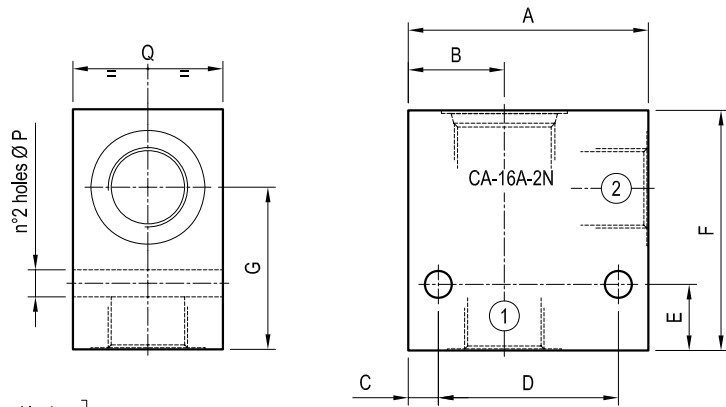

[mm / Inches]

80 (3.15)	32 (1.26)	10 (0.39)	60 (2.36)	22 (0.87)	80 (3.15)	54 (2.13)	-	-	-	-	-	-	-	9 (0.35)	50 (1.97)	-	-	-	G 3/4
90 (3.54)	37 (1.46)	10 (0.39)	60 (2.36)	22 (0.87)	80 (3.15)	54 (2.13)	-	-	-	-	-	-	9 (0.35)	50 (1.97)	-	-	-	-	G 1
A	B	C	D	E	F	G	H	I	L	M	N	O	P	Q	R	S	PORTS		

CAVITY: CA-16A-3C

	Ordering code	Ports 1-2	3	Weight kg (lbs)
Aluminium	OC1009274 R934000235	G 3/4	G 1/4	0.80 (1.76)
	OC1009272 R934000233	G 1	G 1/4	0.87 (1.92)
Steel	OC1009275 R934000236	G 3/4	G 1/4	2.23 (4.92)
	OC1009273 R934000234	G 1	G 1/4	2.45 (5.40)

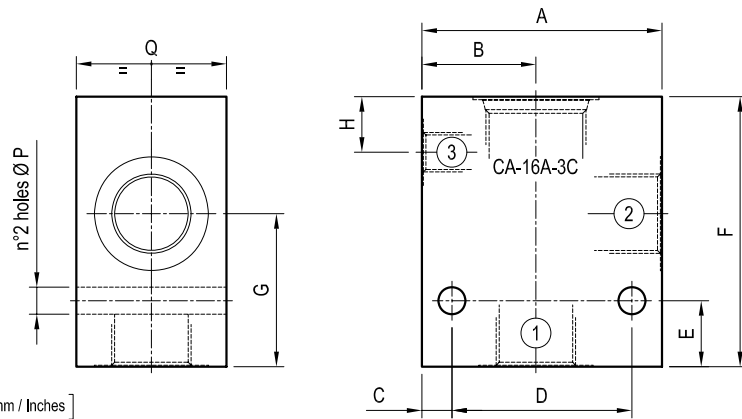

[mm / Inches]

80 (3.15)	38 (1.50)	10 (0.39)	60 (2.36)	22 (0.87)	90 (3.54)	51 (2.01)	18.5 (0.73)	-	-	-	-	-	9 (0.35)	50 (1.97)	-	-	-	-	G 3/4
90 (3.54)	40 (1.58)	10 (0.39)	70 (2.76)	22 (0.87)	90 (3.54)	51 (2.01)	18.5 (0.73)	-	-	-	-	-	9 (0.35)	50 (1.97)	-	-	-	-	G 1
A	B	C	D	E	F	G	H	I	L	M	N	O	P	Q	R	S	PORTS		

CAVITY: CA-16A-3C (DOUBLE CAVITY)

	Ordering code	Ports V1-V2-C1-C2	Weight kg (lbs)
Aluminium	OC1009195 R934000156	G 1	1.34 (2.95)
Steel	OC1009194 R934000155	G 1	3.74 (8.25)

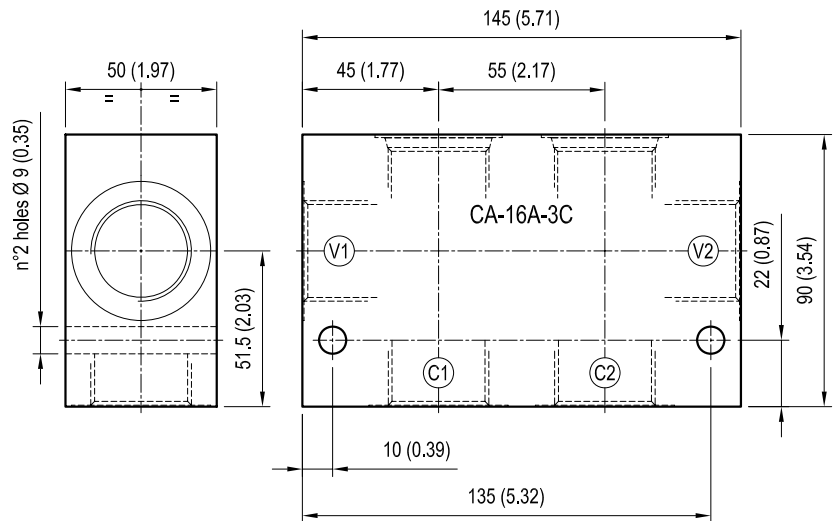

[mm / Inches]

Standard manifolds - Common cavity

Size 16 - Aluminium / Steel

CAVITY: CA-16A-3N

	Ordering code	Ports 1-2-3	Weight kg (lbs)
Aluminium	OC1009228 R934000189	G 3/4	0.98 (2.16)
	OC1009230 R934000191	G 1	1.11 (2.45)
Steel	OC1009229 R934000190	G 3/4	2.76 (6.09)
	OC1009231 R934000192	G 1	3.11 (6.86)

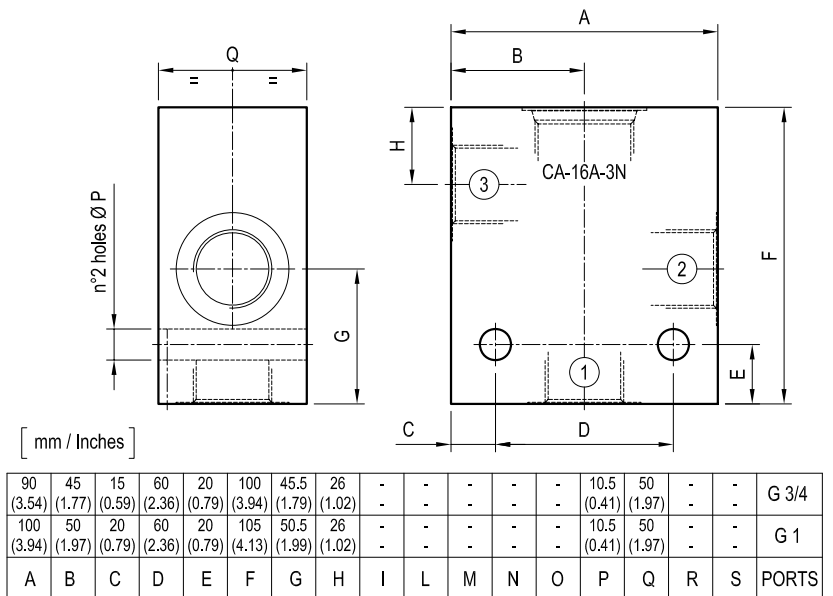

CAVITY: CA-16A-4N

	Ordering code	Ports 1-2-3-4	Weight kg (lbs)
Aluminium	OC1009244 R934000205	G 3/4	1.28 (2.82)
	OC1009246 R934000207	G 1	1.36 (3.00)
Steel	OC1009245 R934000206	G 3/4	3.59 (7.92)
	OC1009247 R934000208	G 1	3.81 (8.40)

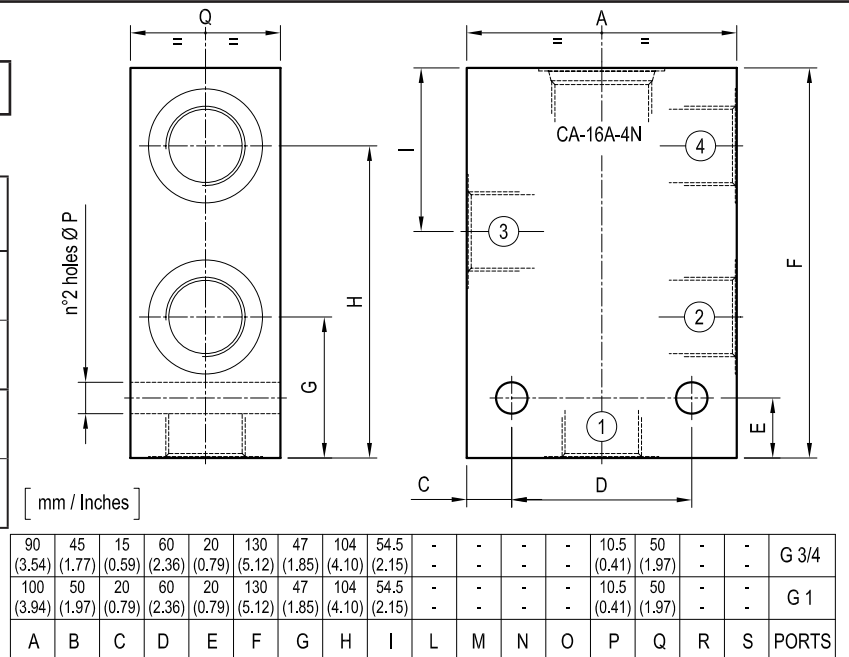

CAVITY: CA-16A-4N (Port 1 closed)

	Ordering code	Ports 1-2-3-4	Weight kg (lbs)
Aluminium	OC1009256 R934000217	G 3/4	1.19 (2.62)
	OC1009258 R934000219	G 1	1.28 (2.82)
Steel	OC1009257 R934000218	G 3/4	3.34 (7.36)
	OC1009259 R934000220	G 1	3.58 (7.89)

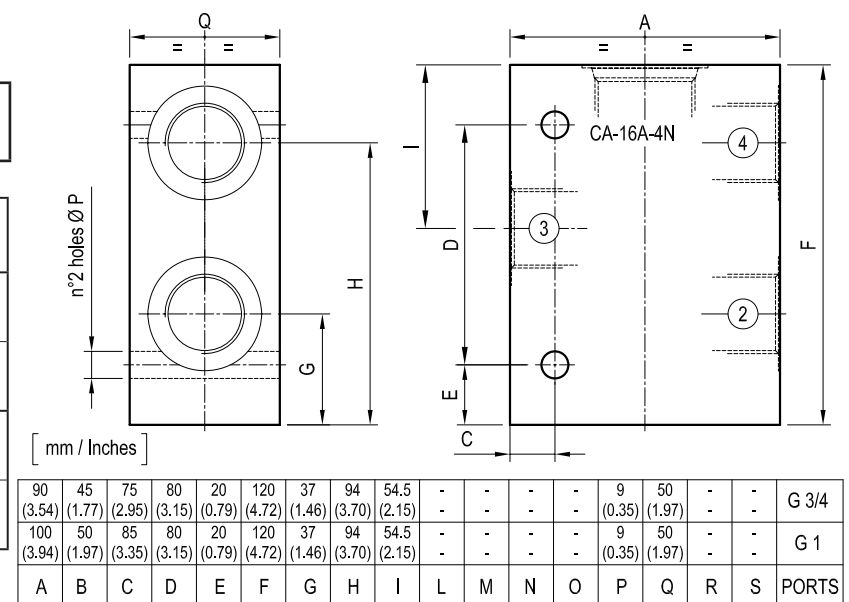

Standard manifolds - Common cavity Size 20 - Aluminium / Steel

CAVITY: CA-20A-2N

	Ordering code	Ports 1-2	Weight kg (lbs)
Aluminium	OC1009223 R934000184	G 1	1.3 (2.87)
	OC1009221 R934000182	G 1-1/4	1.21 (2.67)
Steel	OC1009224 R934000185	G 1	3.65 (8.05)
	OC1009222 R934000183	G 1-1/4	3.40 (3.50)

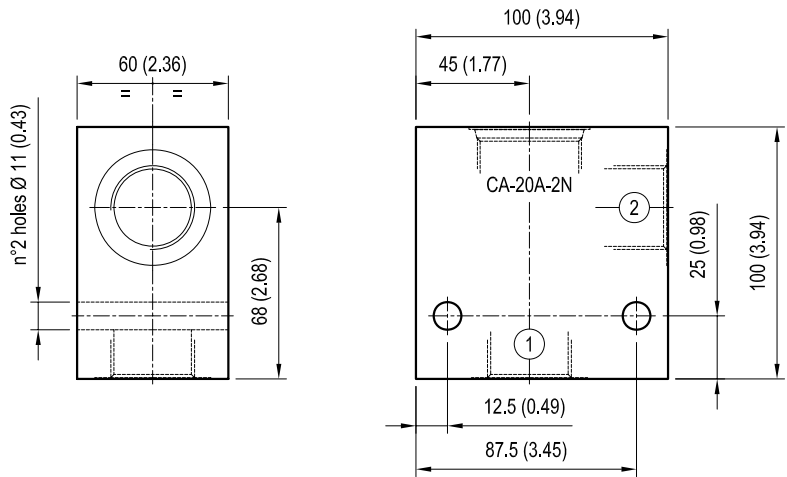

[mm / Inches]

CAVITY: CA-20A-3C

	Ordering code	Ports 1-2 3	Weight kg (lbs)
Aluminium	OC1009278 R934000239	G 1 G 1/4	1.43 (3.15)
	OC1009276 R934000237	G 1-1/4 G 1/4	1.35 (2.98)
Steel	OC1009279 R934000240	G 1 G 1/4	4.02 (8.86)
	OC1009277 R934000238	G 1-1/4 G 1/4	3.78 (8.33)

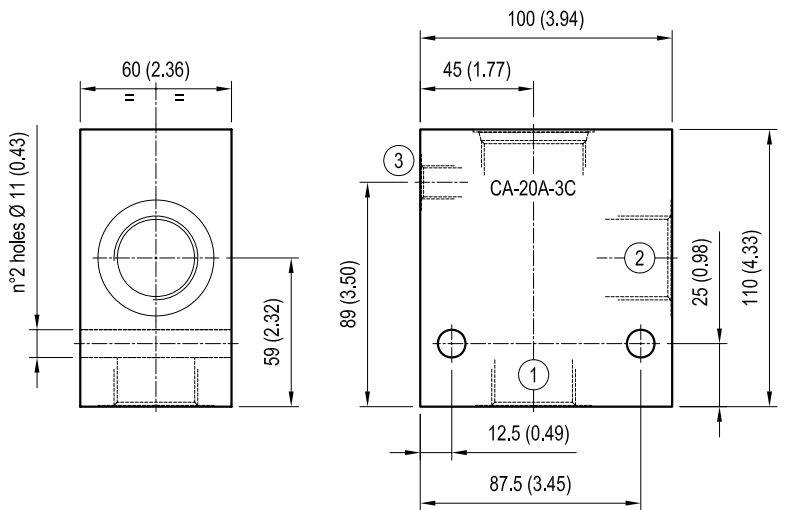

[mm / Inches]

**CAVITY: CA-20A-3C
(DOUBLE CAVITY)**

	Ordering code	Ports V1-V2-C1-C2	Weight kg (lbs)
Aluminium	OC1009197 R934000158	G 1-1/4	2.53 (5.58)
Steel	OC1009196 R934000157	G 1-1/4	7.11 (15.68)

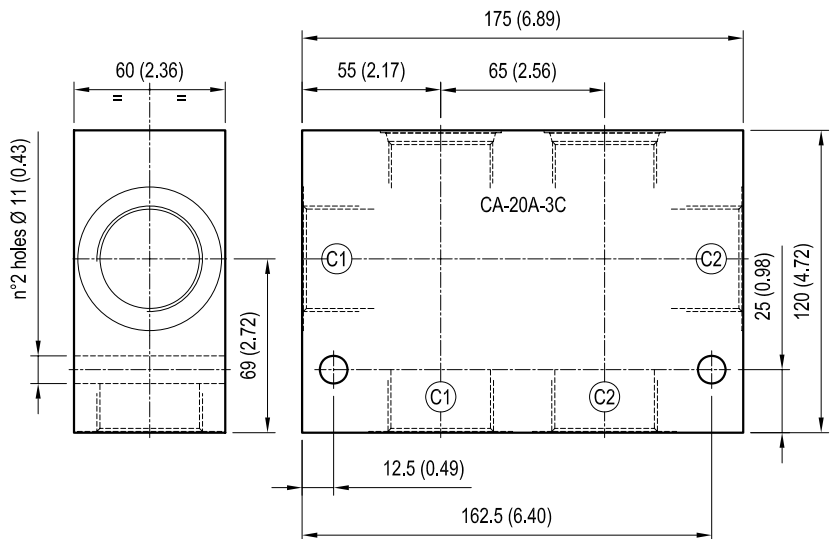

[mm / Inches]

Standard manifolds - Common cavity Size 20 - Aluminium / Steel

CAVITY: CA-20A-3N

	Ordering code	Ports 1-2-3	Weight kg (lbs)
Aluminium	OC1009234 R934000195	G 1	2.15 (1.61)
	OC1009232 R934000193	G 1-1/4	2.02(1.52)
Steel	OC1009235 R934000196	G 1	6.02 (4.50)
	OC1009233 R934000194	G 1-1/4	5.66 (4.26)

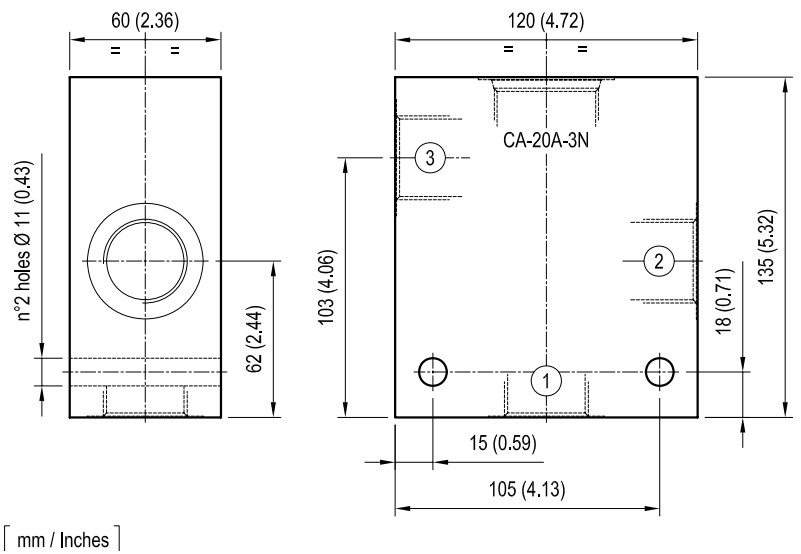

[mm / Inches]

CAVITY: CA-20A-4N

	Ordering code	Ports 1-2-3-4	Weight kg (lbs)
Aluminium	OC1009248 R934000209	G 1	2.78 (6.13)
	OC1009250 R934000211	G 1-1/4	2.60 (5.73)
Steel	OC1009249 R934000210	G 1	7.80 (17.20)
	OC1009251 R934000212	G 1-1/4	7.30 (16.10)

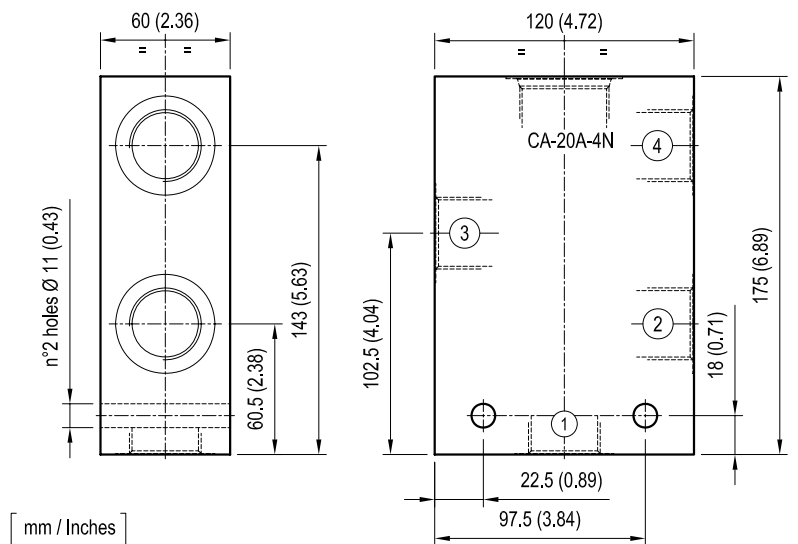

[mm / Inches]

Standard manifolds - Special cavity Aluminium / Steel

CAVITY: 017-E

	Ordering code	Ports 1-2	Weight kg (lbs)
Aluminium	OC1009015 R901180260	G 1/2	0.32 (0.71)
	OC1009012 R900990630	G 3/4	0.30 (0.66)
Steel	OC1009074 R988004951	G 1/2	0.90 (1.98)
	OC1009073 R901184887	G 3/4	0.83 (1.83)

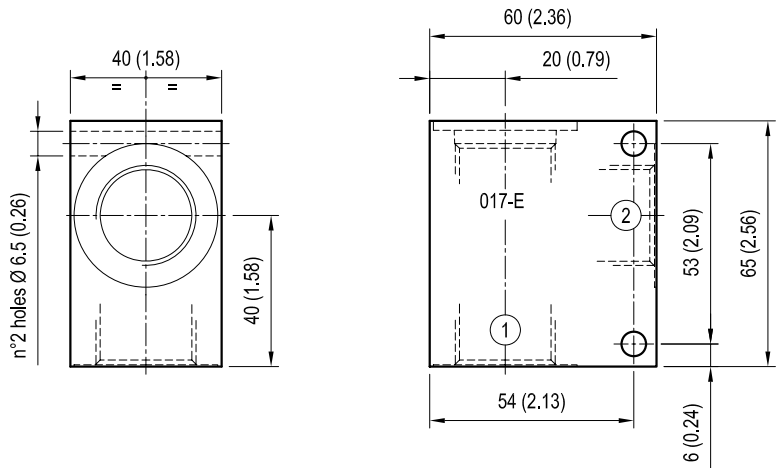

[mm / Inches]

CAVITY: 021-E

	Ordering code	Ports 1-2	Weight kg (lbs)
Aluminium	OC1009017 R934000102	G 3/4	0.68 (1.50)
	OC1009019 R900068903	G 1	0.65 (1.43)
Steel	OC1009075 R900766822	G 3/4	1.89 (4.17)
	OC1009076 R901132883	G 1	1.78 (3.92)

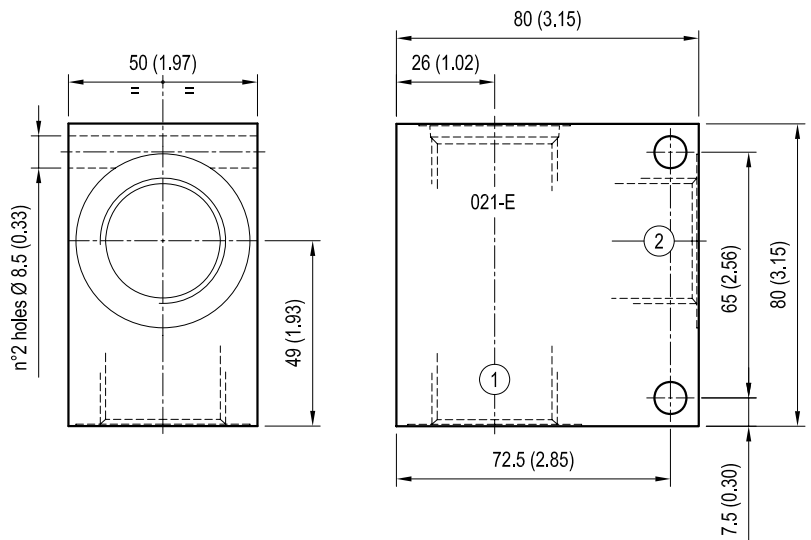

[mm / Inches]

CAVITY: 019-E

	Ordering code	Ports 1-2	Weight kg (lbs)
Aluminium	OC1009103 R901090812	G 1/4	0.17 (0.38)
	OC1009054 R901090792	G 3/8	0.16 (0.35)
Steel	OC1009102 R901090811	G 1/4	0.46 (1.01)
	OC1009101 R901090810	G 3/8	0.44 (0.97)

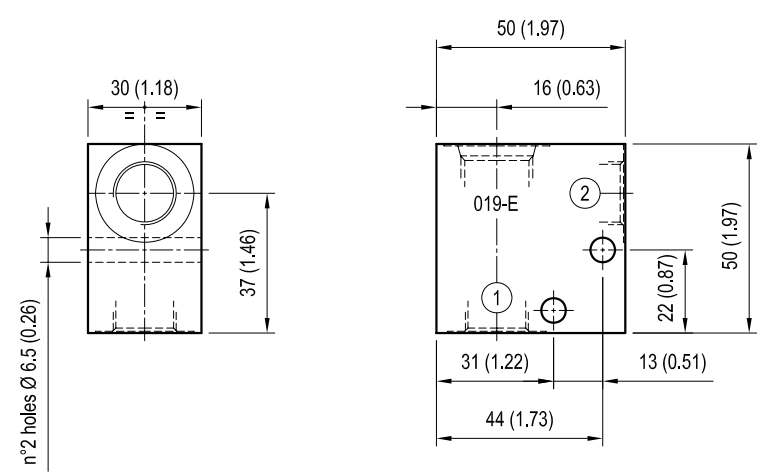

[mm / Inches]

Standard manifolds - Special cavity Aluminium / Steel

CAVITY: 004

	Ordering code	Ports 1-2	Weight kg (lbs)
Aluminium	OC1009040 R901090789	G 1	1.35 (2.98)
	OC1009041 R901090791	G 1-1/4	1.28 (2.82)
Steel	OC1009122 R901090813	G 1	3.74 (8.25)
	OC1009056 R901090794	G 1-1/4	3.52 (7.76)

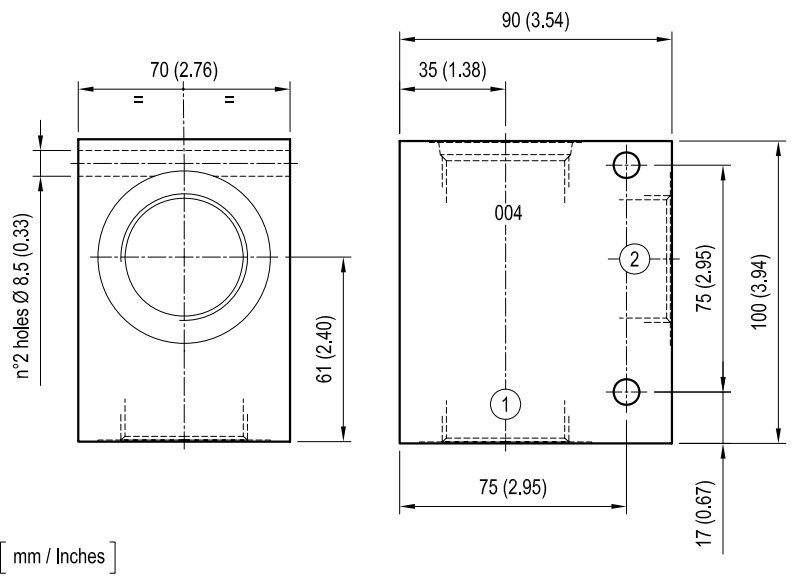

Manifolds with emergency screw Aluminium / Steel

CAVITY: CA-08A-2N

	Ordering code	Ports 1-2	Weight kg (lbs)
Aluminium	OE150009 R934001566	G 1/4	0.26 (0.57)
	OE150002 R934001554	G 3/8	0.25 (0.55)
Steel	OE1500090055 R934001567	G 1/4	0.69 (1.52)
	OE1500020055 R934001555	G 3/8	0.66 (1.46)

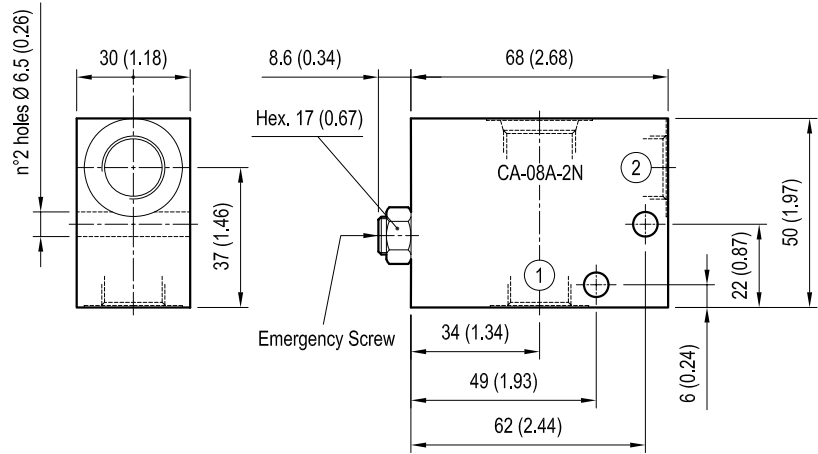

[mm / Inches]

CAVITY: 017-E

	Ordering code	Ports 1-2	Weight kg (lbs)
Aluminium	OE150003 R934001557	G 3/4	0.48 (1.06)
	OE150004 R901121824	G 1	0.47 (1.04)
Steel	OE1500030055 R934001558	G 1/2	1.32 (2.91)
	OE1500040055 R934001561	G 3/4	1.24 (2.73)

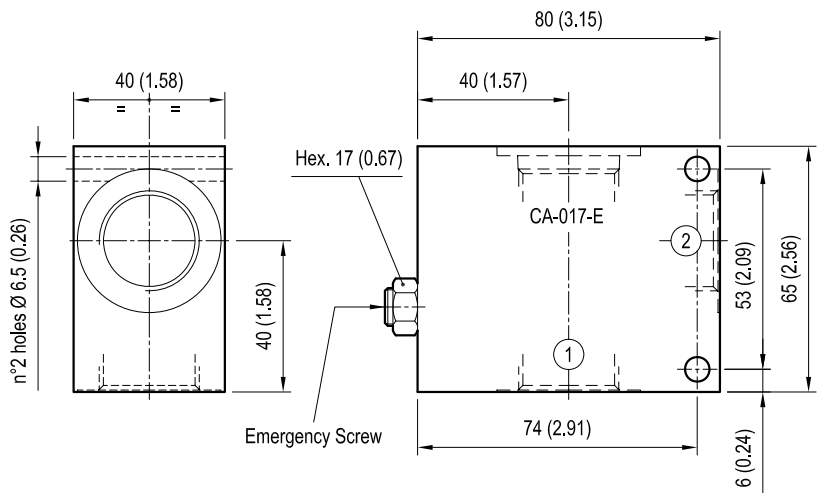

[mm / Inches]

CAVITY: 021-E

	Ordering code	Ports 1-2	Weight kg (lbs)
Aluminium	OE150005 R934001563	G 1	0.77 (1.70)
Steel	OE1500050055 R934001564	G 1	2.10 (4.63)

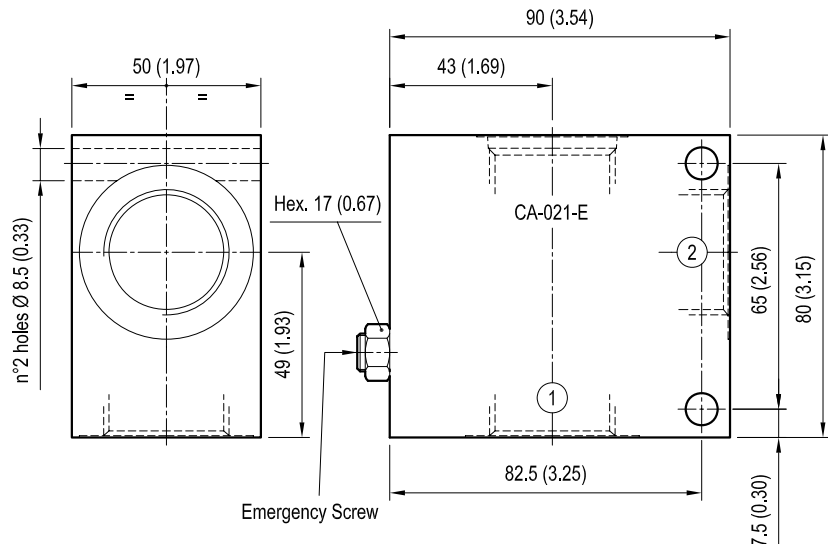

[mm / Inches]

