

**TIPOLOGIA DELLE LANTERNE DISPONIBILI / TYPE OF AVAILABLE BELLHOUSINGS**

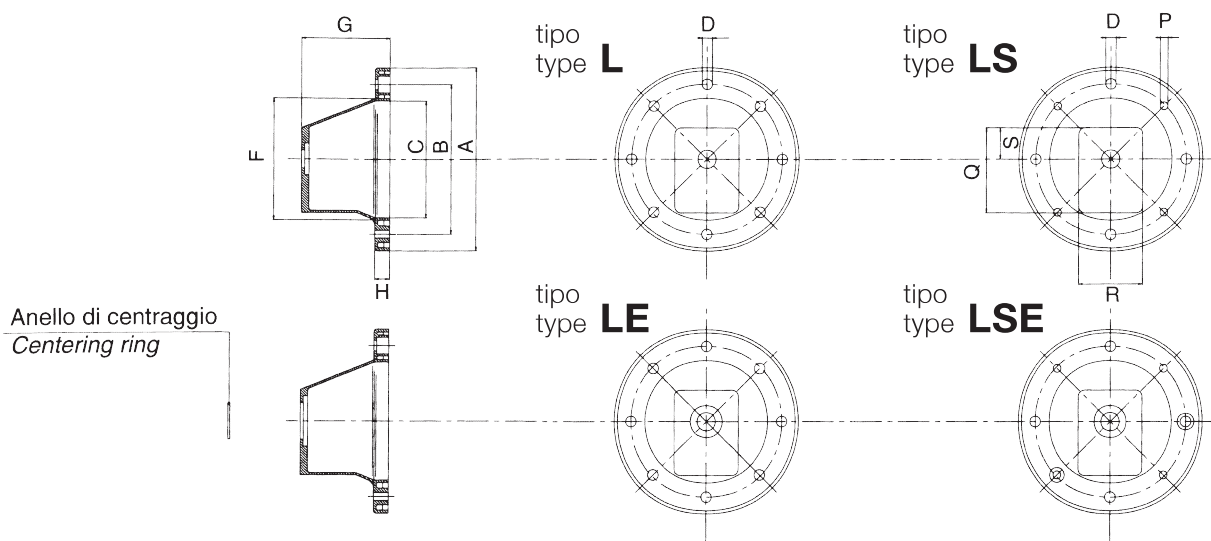

- L** 8 fori passanti lato motore  
8 passing holes on motor side
- LS** 4 fori passanti + 4 fori filettati lato motore  
4 passing holes + 4 threaded holes on motor side

- LE** 8 fori passanti lato motore e anello di centraggio in lamiera per estrazione del giunto  
8 passing holes on motor side + sheet metal centering ring for the extraction of the coupling.
- LSE** 4 fori passanti + 4 fori filettati lato motore e anello di centraggio in lamiera per estrazione del giunto  
4 passing holes + 4 threaded holes on motor side + sheet metal centering ring for the extraction of the coupling.

Tabella / Table 20

Potenza motore 4 poli 1450 giri/1' Motor power 4 poles 1450 revs/min			Semigiunto lato motore Motor side halfcoupling						
kW	Taglia Size	HP	Codice Part number	Dimensioni / Dimensions (mm)					
				A	C	G	D	CH	T
0,12	63	0,16	ND 48A	48	30	19	11	4	12,8
0,18		0,25							
0,25	71	0,35	ND 48B	48	30	29	14	5	16,3
0,37		0,5							
0,55	80	0,75	ND 48C	48	38	54	19	6	21,8
0,75		1,1							
1,1	90	1,5	ND 48D	48	38	54	24	8	27,3
1,5		2							
0,55	80	0,75	ND 65A	65	42	47,5	19	6	21,8
0,75		1,1							
1,1	90	1,5	ND 65B	65	48	47,5	24	8	27,3
1,5		2							
2,2	100	3	ND 65C	65	53	57,5	28	8	31,3
4		5,5							
2,2	100	3	ND 86A	86	55	60	28	8	31,3
4		5,5							
5,5	132	7,5	ND 86B	86	73	88	38	10	41,3
9		12,5							
5,5	132	7,5	ND 108A	108	73	77	38	10	41,3
9		12,5							
11	160	15	ND 108B	108	84	110	42	12	45,3
15		20							
18,5	180	25	ND 108C	108	100	110	48	14	51,8
22		30							
30	200	40	ND 108D	108	100	110	55	16	59,3
30	200	40	ND 143B	143	106	110	55	16	59,3
37	225	50	ND 143C	143	137	140	60	18	64,4
45		60							



Tabella / Table 21

Rif. pompa Pump code	Dimensioni (mm) lato pompa / Dimensions (mm) pump side				
	Tipo / Type	d	Ch	t	L
<b>05 M</b>	cilindrico / cylindric	6	2	7	10
<b>05 GT</b>	cilindrico / cylindric	7	2	8	10
<b>1 C</b>	cilindrico / cylindric	12	3	13,3	13,5
<b>U1P</b>	con 1:8 / taper 1:8	9,7	2,4	10,5	15
<b>1M</b>	con 1:8 / taper 1:8	13,9	3	15,5	18,5
<b>2</b>	con 1:8 / taper 1:8	17,2	3,2	18,5	23
<b>2</b>	con 1:8 / taper 1:8	17,2	4	18,5	23
<b>3U</b>	con 1:8 / taper 1:8	22,2	4	23,6	28
<b>35</b>	con 1:8 / taper 1:8	25,6	4,76	27,8	35
<b>35</b>	con 1:8 / taper 1:8	25,6	5	27,8	35
<b>4</b>	con 1:8 / taper 1:8	33,3	6,35	35,5	45
<b>4</b>	con 1:8 / taper 1:8	33,3	7	35,5	45
<b>ZB</b>	con 1:5 / taper 1:5	9,8	2	10,2	12
<b>ZF</b>	con 1:5 / taper 1:5	16,9	3	17,7	19
<b>ZG</b>	con 1:5 / taper 1:5	25,2	5	26,3	29

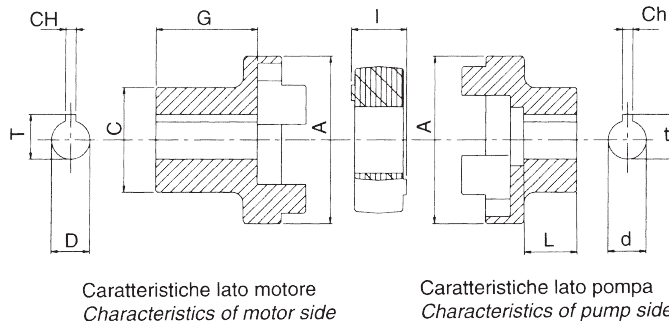

## MOTORI FLANGIA B3-B5 / MOTORS WITH FLANGE B3-B5

kW	Taglia Size	HP	Motore 4 poli 1450 giri/1' Motor power 4 p. 1450 revs/min	Rif. pompa Pump code	Lanterna Bellhousing				Dimensione lanterna (mm) Dimensions of bellhousing (mm)								Giunto completo serie ND Complete coupling ND series		Semigiunto Motore Halfcoupling motor side	Insero elastico Rubber spider	Semigiunto pompa Halfcoupling pump side	Anelli di centraggio Centering ring	Piedino Foot flange	Anello Amm. Suitable damping ring			
					LE	LSE	L	LS	A	B	C	D	F	G	H	P	Q	R	S	Codice Part number	H	Codice Part number	Codice Part num.	I	Codice Part number		
5,5 ÷ 9	132	7,5 ÷ 12	U 1 P	3010	310	3010	310	300	265	230	14	238	143	21	M12	170	120	59	ND 900	135	ND 86B	R-82	20	NS 86PU1P	RC1-254	P-300	A-300
			1 C	3011	311	3011	311	300	265	230	14	238	143	21	M12	170	120	59	ND 901	135	ND 86B	R-82	20	NS 86P1C	RC1-30		
			1 M	3011	311	3011	311	300	265	230	14	238	143	21	M12	170	120	59	ND 901A	135	ND 86B	R-82	20	NS 86P1M	RC1-30		
			2	3001	300	3001	300	300	265	230	14	238	143	21	M12	170	120	59	ND 16	135	ND 86B	R-82	20	ND 86P2	RC2-365		
			T 250	3002	301	3002	301	300	265	230	14	238	143	21	M12	170	120	59	ND 17	135	ND 86B	R-82	20	ND 86P3U	RC2-508		
			3 U	3003	302	3003	302	300	265	230	14	238	143	21	M12	170	120	59	ND 17	135	ND 86B	R-82	20	ND 86P3U	RC2-508		
			M 3	3004	303	3004	303	300	265	230	14	238	143	21	M12	170	120	59	ND 17	135	ND 86B	R-82	20	ND 86P3U	RC2-508		
			T 3	3005	304	3005	304	300	265	230	14	238	143	21	M12	170	120	59	ND 17	135	ND 86B	R-82	20	ND 86P3U	RC2-508		
			ZF	-	-	LB26	LBS26	300	265	230	14	238	143	21	M12	170	120	59	ND 210	135	ND 86B	R-82	20	ND 86PZF	-		
			ZG	-	-	LB27	LBS27	300	265	230	14	238	143	21	M12	170	120	59	ND 211	135	ND 86B	R-82	20	ND 86PZG	-		
			35 M	3006	305	3006	305	300	265	230	14	238	143	21	M12	180	158	62	ND 18C	135	ND 108A	R-103	24	ND 108P35	RC3-60		
			35 G	3007	306	3007	306	300	265	230	14	238	143	21	M12	180	158	62	ND 18C	135	ND 108A	R-103	24	ND 108P35	RC3-603		
			35 U	3007	306	3007	306	300	265	230	14	238	143	21	M12	180	158	62	ND 18C	135	ND 108A	R-103	24	ND 108P35	RC3-603		
			2	-	-	3511	350	350	300	250	18	253	178	25	M16	235	235	117,5	ND 43A	168	ND 108B	R-103	24	ND 108P2	RC2S-365		
			T 250	3512	351	3512	351	350	300	250	18	253	178	25	M16	235	235	117,5	ND 43C	168	ND 108B	R-103	24	ND 108P3U	RC3-508		
3 U	3513	352	3513	352	350	300	250	18	253	178	25	M16	235	235	117,5	ND 43C	168	ND 108B	R-103	24	ND 108P3U	RC3-508					
M 3	3514	353	3514	353	350	300	250	18	253	178	25	M16	235	235	117,5	ND 43C	168	ND 108B	R-103	24	ND 108P3U	RC2S508					
T 3	3515	354	3515	354	350	300	250	18	253	178	25	M16	235	235	117,5	ND 43C	168	ND 108B	R-103	24	ND 108P3U	RC2S508					
ZF	-	-	LB31	LBS31	350	300	250	18	253	178	25	M16	235	235	117,5	ND 43D	168	ND 108B	R-103	24	ND 108PZF	-					
ZG	-	-	LB32	LBS32	350	300	250	18	253	178	25	M16	235	235	117,5	ND 43E	168	ND 108B	R-103	24	ND 108PZG	-					
35 M	3506	355	-	-	350	300	250	18	253	188	25	M16	230	175	77	ND 21	176	ND 108B	R-103	24	ND 108Q35	RC3-60					
35 G	3507	356	-	-	350	300	250	18	253	188	25	M16	230	175	77	ND 21	176	ND 108B	R-103	24	ND 108Q35	RC3-603					
35 U	3507	356	-	-	350	300	250	18	253	188	25	M16	230	175	77	ND 21	176	ND 108B	R-103	24	ND 108Q35	RC3-603					
4 M	3508	357	-	-	350	300	250	18	253	188	25	M16	230	175	77	ND 22	176	ND 108B	R-103	24	ND 108Q4	RC3-635					
4 T	3508	357	-	-	350	300	250	18	253	188	25	M16	230	175	77	ND 22	176	ND 108B	R-103	24	ND 108Q4	RC3-635					
4 U	3509	358	-	-	350	300	250	18	253	188	25	M16	230	175	77	ND 22	176	ND 108B	R-103	24	ND 108Q4	RC3-635					
2	-	-	3511	350	350	300	250	18	253	178	25	M16	235	235	117,5	ND 44A	168	ND 108C	R-103	24	ND 108P2	RC2S-366					
T 250	3512	351	3512	351	350	300	250	18	253	178	25	M16	235	235	117,5	ND 44C	168	ND 108C	R-103	24	ND 108P3U	RC3-508					
3 U	3513	352	3513	352	350	300	250	18	253	178	25	M16	235	235	117,5	ND 44C	168	ND 108C	R-103	24	ND 108P3U	RC3-508					
M 3	3514	353	3514	353	350	300	250	18	253	178	25	M16	235	235	117,5	ND 44C	168	ND 108C	R-103	24	ND 108P3U	RC2S-508					
T 3	3515	354	3515	354	350	300	250	18	253	178	25	M16	235	235	117,5	ND 44C	168	ND 108C	R-103	24	ND 108P3U	RC2S-508					
ZF	-	-	LB31	LBS31	350	300	250	18	253	178	25	M16	235	235	117,5	ND 44D	168	ND 108C	R-103	24	ND 108PZF	-					
ZG	-	-	LB32	LBS32	350	300	250	18	253	178	25	M16	235	235	117,5	ND 44E	168	ND 108C	R-103	24	ND 108PZG	-					
35 M	3506	355	-	-	350	300	250	18	253	188	25	M16	230	175	77	ND 25	176	ND 108C	R-103	24	ND 108Q35	RC3-60					
35 G	3507	356	-	-	350	300	250	18	253	188	25	M16	230	175	77	ND 25	176	ND 108C	R-103	24	ND 108Q35	RC3-603					
35 U	3507	356	-	-	350	300	250	18	253	188	25	M16	230	175	77	ND 25	176	ND 108C	R-103	24	ND 108Q35	RC3-603					
4 M	3508	357	-	-	350	300	250	18	253	188	25	M16	230	175	77	ND 26	176	ND 108C	R-103	24	ND 108Q4	RC3-635					
4 T	3508	357	-	-	350	300	250	18	253	188	25	M16	230	175	77	ND 26	176	ND 108C	R-103	24	ND 108Q4	RC3-635					
4 U	3509	358	-	-	350	300	250	18	253	188	25	M16	230	175	77	ND 26	176	ND 108C	R-103	24	ND 108Q4	RC3-635					
T 250	4001	400	-	-	400	350	300	18	299	188	25	M16	272	247	123	ND 40	176	ND 108D	R-103	24	ND 108Q3U	RC3-508					
3 U	4002	401	-	-	400	350	300	18	299	188	25	M16	272	247	123	ND 40	176	ND 108D	R-103	24	ND 108Q3U	RC3-508					
M 3	4003	402	-	-	400	350	300	18	299	188	25	M16	272	247	123	ND 40	176	ND 108D	R-103	24	ND 108Q3U	RC3-508					
T 3	4004	403	-	-	400	350	300	18	299	188	25	M16	272	247	123	ND 40	176	ND 108D	R-103	24	ND 108Q3U	RC3-508					
35 M	4005	404	-	-	400	350	300	18	299	188	25	M16	272	247	123	ND 41	176	ND 108D	R-103	24	ND 108Q35	RC3-60					
35 G	4006	405	-	-	400	350	300	18	299	188	25	M16	272	247	123	ND 41	176	ND 108D	R-103	24	ND 108Q35	RC3-603					
35 U	4006	405	-	-	400	350	300	18	299	188	25	M16	272	247	123	ND 41	176	ND 108D	R-103	24	ND 108Q35	RC3-603					
4 M	4007	406	-	-	400	350	300	18	299	188	25	M16	272	247	123	ND 42	176	ND 108D	R-103	24	ND 108Q4	RC3-635					
4 T	4007	406	-	-	400	350	300	18	299	188	25	M16	272	247	123	ND 42	176	ND 108D	R-103	24	ND 108Q4	RC3-635					
4 U	4008	407	-	-	400	350	300	18	299	188	25	M16	272	247	123	ND 42	176	ND 108D	R-103	24	ND 108Q4	RC3-635					
ZG	-	-	LB30	LBS30	400	350	300	18	299	188	25	M16	272	247	123	ND 299	176	ND 108D	R-103	24	ND 108QZG	-					
T 250	-	-	4505	450	450	400	350	18	350	218	25	M16	287,5	175	137,5	ND 32	206	ND 143C	R-132	29	ND 143P3U	RC3-508					
3 U	-	-	4506	450	450	400	350	18	350	218	25	M16	287,5	175	137,5	ND 32	206	ND 143C	R-132	29	ND 143P3U	RC3-508					
M 3	-	-	4507	450	450	400	350	18	350	218	25	M16	287,5	175	137,5	ND 32	206	ND 143C	R-132	29	ND 143P3U	RC3-508					
T 3	-	-	4508	450	450	400	3																				