

VBSO-SE-NBA

05.43.01 - X - Y - Z

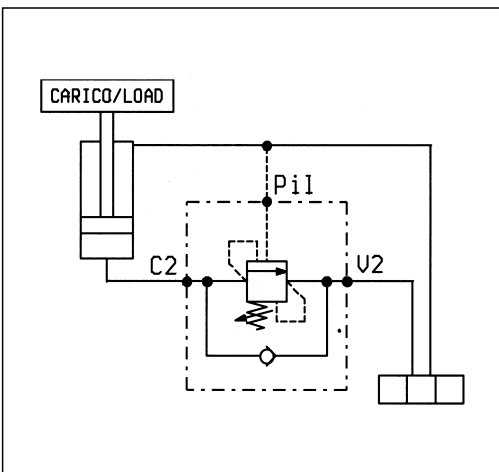

DATI TECNICI / TECHNICAL DATA	
Pressione max. Max. pressure	350 bar
Portata max. Flow max.	40 l/min
Taratura della valvola: almeno 1.3 volte superiore alla pressione indotta dal carico Pressure setting: at least 1.3 times the load induced pressure	
Cappello per piombatura Sealing Cap	Codice/Ordering code 03.05.01.002
Peso Weight	0.67 kg

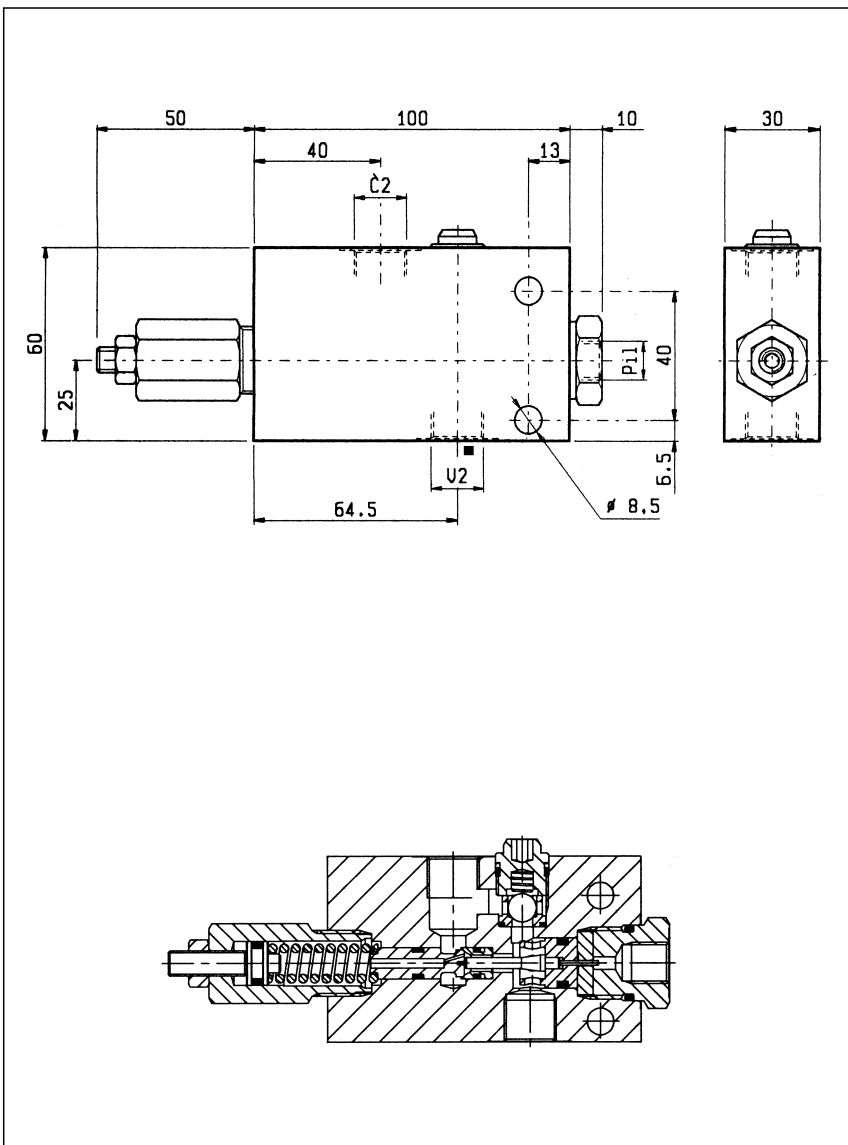
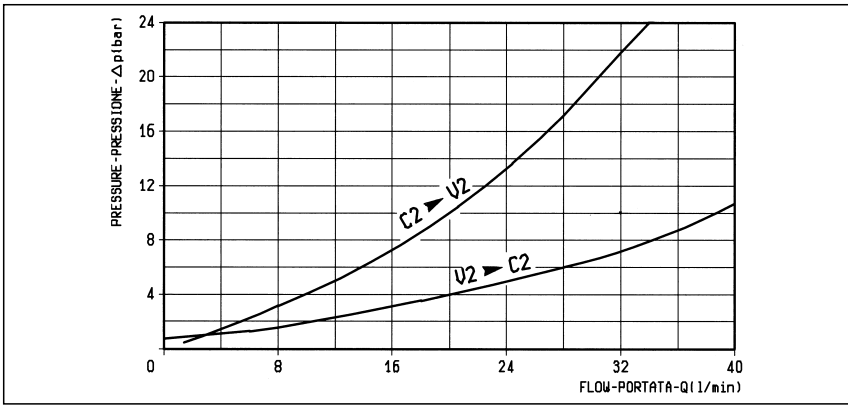

X	RAPPORTO DI PILOTAGGIO PILOT RATIO
37	9.1 : 1
10	3.6 : 1
39	2 : 1

Z	MOLLE / SPRINGS				
	Campo taratura min - max bar Adj. press. range bar	Incremento press. bar / giro vite Press. increase bar / turn	Taratura standard bar (Q = 5 l/min) Std. setting bar (made at 5 l/min)	Cod. ordinazione Ordering code	Colore Colour
20	60-210	50	200	03.51.01.075	verde green
35	100-350	88	350	03.51.01.059	giallo yellow

Y	ATTACCHI / PORT SIZE	
	V2-C2	PIL
02	G 3/8	G 1/4