

RE 18307-21/04.10

1/2

Replaces: RE 00171/02.07

Pilot operated check, dual



VSO-DE-DL

05.53.03 - X - 09 - Z

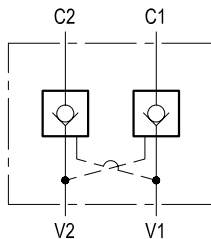

Description

Flow is allowed to pass in one direction (V1 to C1 or V2 to C2), then the valve remains closed (checked) in both reverse directions (C1 to V1 or C2 to V2) in order to hold and lock in position the cylinder or other actuators; reverse flow is possible only when sufficient pilot pressure is applied at V2 or V1, which act as cross connected pilot ports, and the pilot piston lifts the poppet from its seat overcoming cylinder port pressure.

Performance

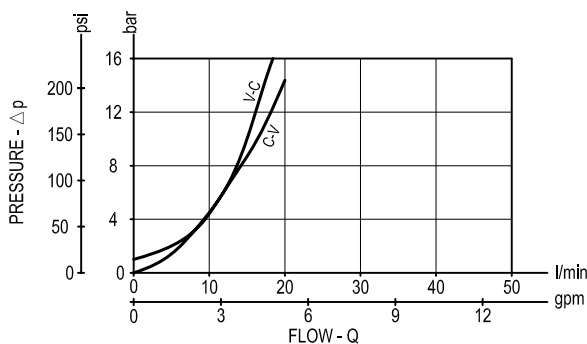

Technical data

Hydraulic

Operating pressure	bar (psi)	350 (5000)
--------------------	-----------	------------

Max. flow	l/min (gpm)	20 (5)
-----------	-------------	--------

The version with O-Ring and heavier spring is generally recommended.

General

Manifold material	Aluminium
-------------------	-----------

Note: aluminium bodies are often strong enough for operating pressures exceeding 210 bar (3000 psi), depending from the fatigue life expected in the specific application. If in doubt, consult our Service Network.

Weight	kg (lbs)	0.7 (1.5)
--------	----------	-----------

Fluid temperature range	°C (°F)	between -30 (-22) and +100 (212)
-------------------------	---------	----------------------------------

Other technical data	see data sheet RE 18350-50
----------------------	----------------------------

Note: for applications outside these parameters, please consult us.

Dimensions

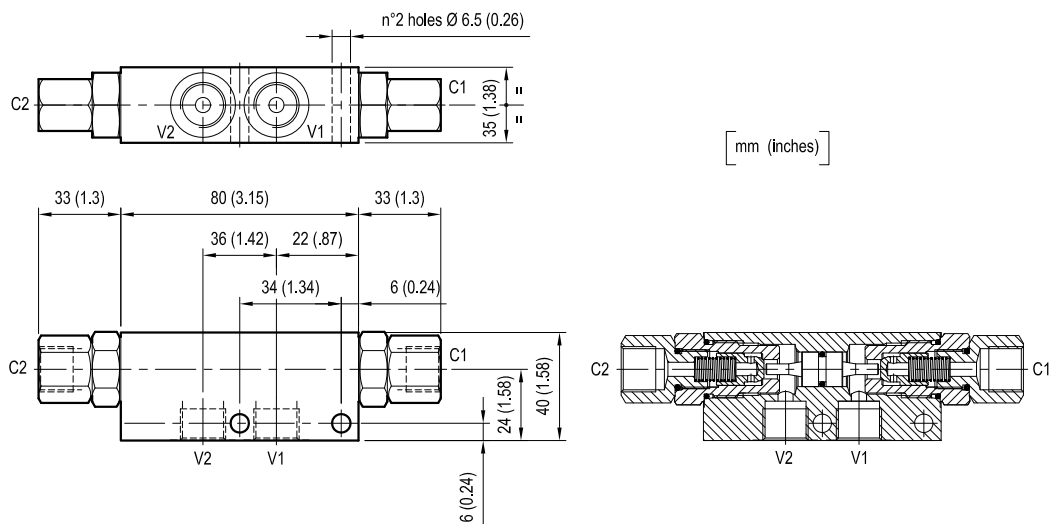

Ordering code

05.53.03 X 09 Z

Pilot operated check, dual

O-Ring on pilot piston	Pilot ratio	
= 00	No O-Ring	4 : 1
= 10	With O-Ring	4 : 1
= 37	No O-Ring	9 : 1

Port sizes	V1 - V2	C1 - C2
	G 1/4	G 1/4

SPRINGS		
Cracking pressure bar (psi)		
= 00	only for X=00 and X=37	3 (44)
= 01	for X=00, X=10 and X=37	8 (116)

Type	Material number
055303000900000	R930002424
055303000901000	R930002425
055303100901000	R930002433
055303370900000	R930002437
055303370901000	R930002438

Type	Material number