

RE 18307-47/04.10

1/2

Replaces: RE 00171/02.07

Single counterbalance, relief compensated

A-VBSO-SE-CC-30

08.43.96 - X - Y - Z

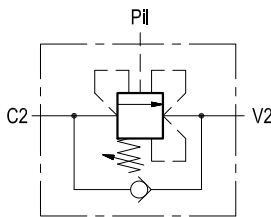
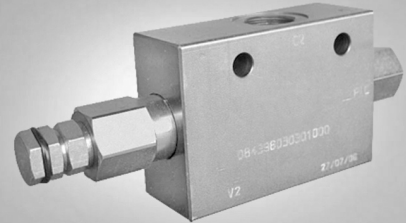

Description

When pressure at V2 rises above the spring bias pressure, the check seat is pushed away from the piston and flow is allowed from V2 to C2. When load pressure at C2 rises above the setting, the direct-acting relief function is activated and flow is relieved from C2 to V2. With pilot pressure at P11, the pressure setting is reduced in proportion to the stated ratio, until opening and allowing flow from C2 to V2. The spring chamber is drained to V2. The valve applies a balanced piston allowing relief at the valve setting independent of back-pressure at V2. However, the piloted opening of the valve remains subject to additive pressure at port V2.

Performance

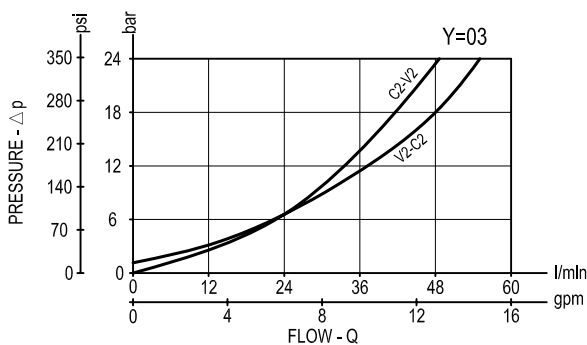

Technical data

Hydraulic

Max. operating pressure	bar (psi)	350 (5000)
-------------------------	-----------	------------

Max. flow	l/min (gpm)	60 (16)
-----------	-------------	---------

Relief setting: at least 1.3 times the highest expected load.

General

Manifold material	Steel
-------------------	-------

Weight	see "Dimensions"
--------	------------------

Fluid temperature range	°C (°F)	between -30 (-22) and +100 (212)
-------------------------	---------	----------------------------------

Other technical data	see data sheet RE 18350-50
----------------------	----------------------------

Note: for applications outside these parameters, please consult us.

Dimensions

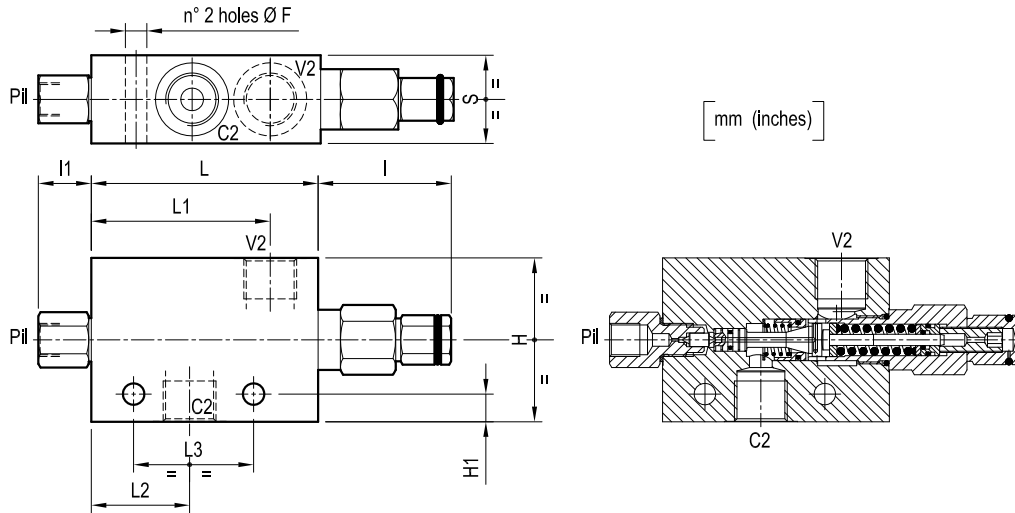

[mm (inches)]

35 (1.38)	47.6 (1.87)	39.3 (1.55)	70.3 (2.77)	91 (3.58)	21 (0.83)	53 (2.09)	11 (0.43)	65 (2.56)			8.5 (0.34)			G 1/2	1.55 (3.42)
30 (1.18)	47.6 (1.87)	39.3 (1.55)	70.3 (2.77)	91 (3.58)	21 (0.83)	53 (2.09)	7 (0.28)	55 (2.17)			8.5 (0.34)			G 3/8	1.15 (2.54)
S	L3	L2	L1	L	I1	I	H1	H			F			Y	Weight kg (lbs)

Ordering code

08.43.96 X Y Z

Single counterbalance,
relief compensated

Pilot ratio

= 03 4.2:1

Port sizes	V2	C2	P11
= 02	G 3/8	G 3/8	G 3/8
= 03	G 1/2	G 1/2	G 1/4

SPRINGS			
	Adj. pressure range bar (psi)	Pres. increase bar/turn (psi/turn)	Std. setting Q=5 (l/min.) bar (psi)
= 20	60-210 (870-3000)	75 (1088)	200 (2900)
= 35	100-350 (1450-5000)	165 (2393)	350 (5000)

Type	Material number
084396030220000	R930003342
084396030235000	R930003343
084396030320000	R930003345
084396030335000	R930003346

Type	Material number