

RE 18309-38/04.10

1/2

Replaces: RE 00171/02.07

# Flow regulator, 3-way, pressure compensated

VRFC3

OM.32.03 - X - Y

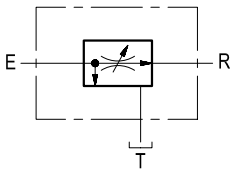

## Description

A constant flow rate, regardless of system pressures, is established from E to R, while a minimum pressure differential of appr. 5 bar (70 psi) exists between the two ports. Input flow supplied to E in excess of the regulated output at R is by-passed to T. Output flow can be varied from closed to the nominal maximum rating for the valve. Reverse flow from R to E is limited by the selected opening of the restrictor and is not pressure compensated. Flow from T to E or from T to R is not possible. Increasing or decreasing inlet flow may cause slight increase or decrease of Regulated flow.

## Performance

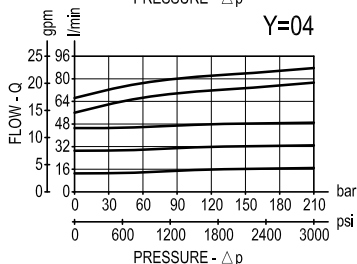
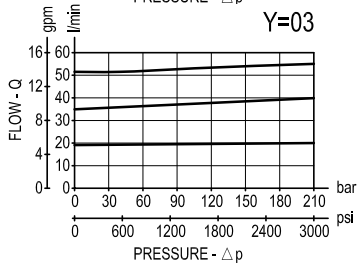
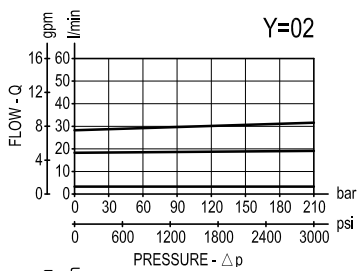

## Technical data

### Hydraulic

Operating pressure bar (psi) up to 210 (3000)

QE = max inlet flow "E" port (see "Dimensions")

QR = max regulated flow "R" port (see "Dimensions")

Flow range adjustment : 0 - 3 turns

### General

Manifold material Aluminium

Note: aluminium bodies are often strong enough for operating pressures exceeding 210 bar (3000 psi), depending from the fatigue life expected in the specific application. If in doubt, consult our Service Network.

Weight see "Dimensions"

Fluid temperature range °C (°F) between -30 (-22) and +100 (212)

Other technical data see data sheet RE 18350-50

**Note:** for applications outside these parameters, please consult us.

Dimensions

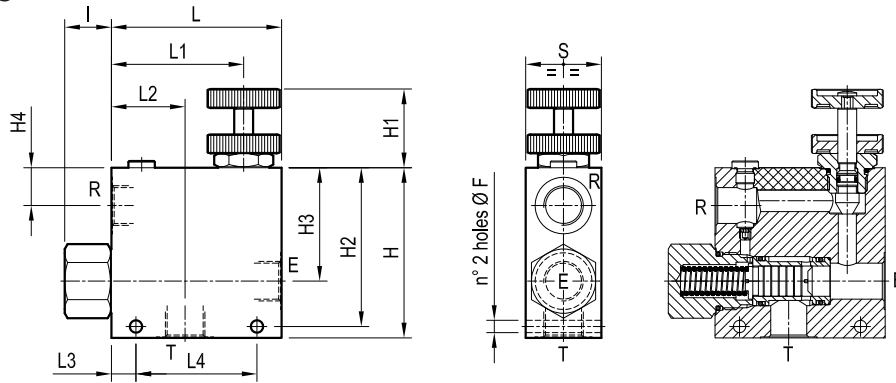

50 (1.97)	88 (3.47)	10 (0.39)	44 (1.73)	79 (3.11)	108 (4.25)	25 (0.98)	23 (0.91)	73 (2.87)	101 (3.98)	40 (1.58)	108 (4.25)	8.5 (0.34)	90 l/min 24 gpm	150 l/min 40 gpm	G 3/4	1.95 (4.3)
40 (1.58)	64 (2.52)	13 (0.51)	39 (1.54)	70 (2.76)	90 (3.54)	25 (0.98)	17.5 (0.69)	60 (2.36)	84 (3.31)	40 (1.58)	90 (3.54)	6.5 (0.26)	55 l/min 15 gpm	90 l/min 24 gpm	G 1/2	1.06 (2.34)
40 (1.58)	64 (2.52)	13 (0.51)	39 (1.54)	70 (2.76)	90 (3.54)	25 (0.98)	17.5 (0.69)	60 (2.36)	84 (3.31)	40 (1.58)	90 (3.54)	6.5 (0.26)	30 l/min 8 gpm	55 l/min 15 gpm	G 3/8	1.06 (2.34)
S	L4	L3	L2	L1	L	I	H4	H3	H2	H1	H	F	QR	QE	Y	Weight kg (lbs)

[ mm (inches) ]

Ordering code

**OM.32.03 X Y**

Flow regulator,  
3-way, pressure compensated

Adjustments

= 70 Handknob and locknut



= 80 Screw and locknut



= 40 Graduated handknob



Port sizes	E - R - T
= 02	G 3/8
= 03	G 1/2
= 04	G 3/4

Type	Material number
OM3203700200000	R930004231
OM320370030000A	R930004232
OM3203700400000	R930004233
OM3203800200000	R930004241
OM320380030000A	R930004242
OM3203800400000	R930004244

Type	Material number
OM3203400200000	R930004220
OM320340030000A	R930004221
OM3203400400000	R930004224