

**FLOW CONTROL VALVES
CARTRIDGE RESTRICTORS**

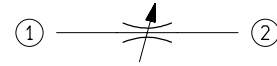

ST-C-12

OD.21.01 - X - 05

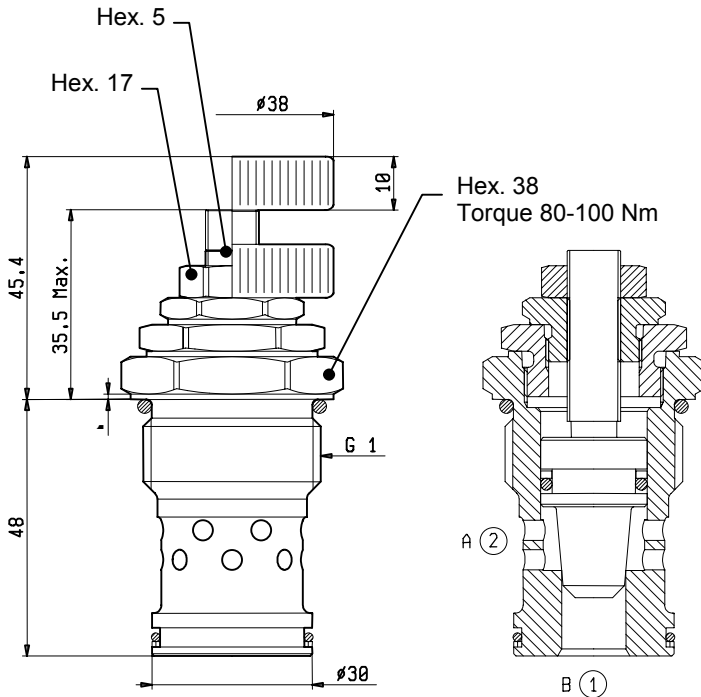

TECHNICAL DATA

Maximum Operating Pressure	350	bar
Rated Flow	150	l/min
Cavity - Tooling (021-E)	page 7.01.110	
Weight	0.310	kg
Fluids - Temperatures	page 7.01.040	
Testing Conditions - Seals	page 7.01.040	
Internal Leakage	page 7.01.040	
Filtration : 25 µm nominal or better	page 7.01.050	
Adjustment Torque at 10 bar	1	Nm
Adjustment Torque at 350 bar	18	Nm
Mounting Position	unrestricted	

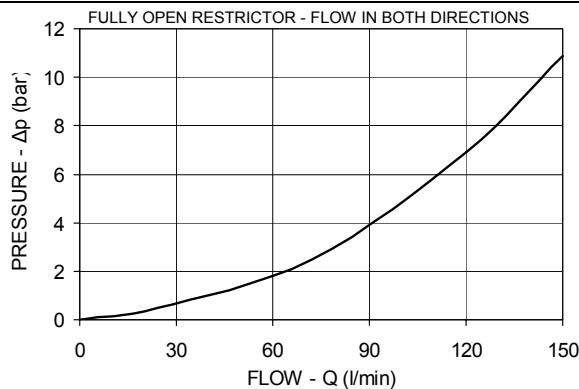

X ORDERING OPTIONS

03 Socket Screw

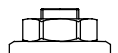

04 Handknob and Locknut

