

Rubrik 8.90

Metric - Taper - Standard

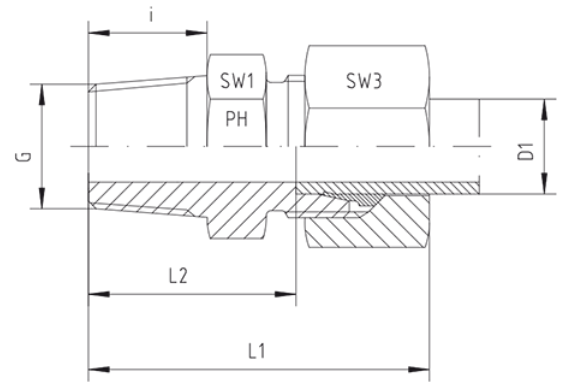
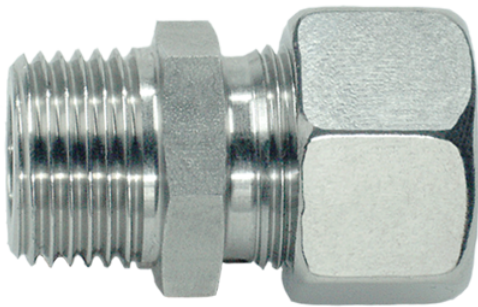

Male Stud Couplings
 LL- and L-Series
 Thread: Metric - Taper

Pressure	Tube O.D.	Thread	Approx. Dimensions					Order-Code
PN	D1	G	L1	L2	i	SW1	SW3	
Series LL								
100	4	M 6 x 1 keg	26,0	16,0	8	10	10	GE-LL-04-M 6x1-k
100	4	M 8 x 1 keg	26,0	16,0	8	10	10	GE-LL-04-M 8x1-k
100	4	M 10 x 1 keg	26,0	16,0	8	11	10	GE-LL-04-M 10x1-k
100	6	M 6 x 1 keg	26,0	14,5	8	11	12	GE-LL-06-M 6x1-k
100	6	M 8 x 1 keg	26,0	14,5	8	11	12	GE-LL-06-M 8x1-k
100	6	M 10 x 1 keg	26,0	14,5	8	11	12	GE-LL-06-M 10x1-k
100	8	M 6 x 1 keg	28,0	16,5	8	12	14	GE-LL-08-M 6x1-k
100	8	M 8 x 1 keg	28,0	16,5	8	12	14	GE-LL-08-M 8x1-k
100	8	M 10 x 1 keg	28,0	16,5	8	12	14	GE-LL-08-M 10x1-k
Series L								
315	6	M 10 x 1 keg	30,5	16,0	8	14	14	GE-L-06-M 10x1-k
315	8	M 12 x 1,5 keg	35,0	20,0	12	17	17	GE-L-08-M 12x1,5-k
315	10	M 14 x 1,5 keg	36,0	21,0	12	17	19	GE-L-10-M 14x1,5-k
315	12	M 16 x 1,5 keg	37,0	22,0	12	19	22	GE-L-12-M 16x1,5-k
315	15	M 18 x 1,5 keg	40,0	23,0	12	24	27	GE-L-15-M 18x1,5-k
315	18	M 22 x 1,5 keg	42,0	25,5	14	27	32	GE-L-18-M 22x1,5-k