

Flow control valve

Serie SRR..



- robust, simple and reliable
- easy coil change without opening the hydraulic envelope
- flow rates are unaffected by temperature change or when the higher load pressure alternates between the outlet ports
- easy to service
- Dependable
- ZnNi coating (>720h NSST)

1 Description

1.1 Generals

The flow control valves of the SRR series are used to set the working speed of hydraulics actuators, the setting being load-independent, and pressure compensated. The flow rate is set by an adjustable slit-type orifice.

When used as a 3-way valve, the higher pressure can be either at the A or the B port. The special orifice design ensures that the flow setting is largely independent of the viscosity of the operating fluid. For a 2-way flow control function please ask Bucher Hydraulics.

Developed specifically for use in load-sensing systems, the valve options /01, /07, /15 and /16 extend the capabilities of

series SRR flow-control valves. Internal connections allow the actual surplus-flow port (R) to be used for picking up the LS signal or for unloading the LS system. These variants enable system designers to create simple, compact and flexible LS applications. As standard, the flow control valves are supplied with proportional solenoids. Options /07 and /16 are controlled by an ON/OFF solenoid.

The pressure relief valve acts on the spring chamber for the pressure compensator. It is set by the manufacturer at the factory according to the customer's requirements and fitted with a safety cap.

1.2 Application examples

- Harvesters
- Sweepers
- Refuse collection vehicles
- Fertiliser spreaders
- Trailered machines
- Mowers
- Road rollers
- Municipal vehicles
- Forestry machines
- Wood chippers

2 Symbols

2.1 2-way flow control valves

2.1.1 Type of operation: Solenoid and emergency pin (S)

SRRB...S2...

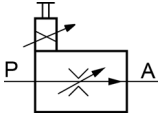

SRRB...S2.../01

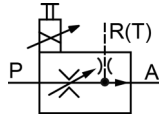

SRRB...S2.../07

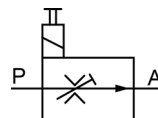

SRRB...S2.../15

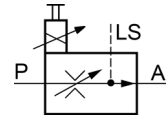

SRRB...S2.../16

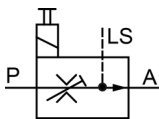

2.1.2 Type of operation: Solenoid and basic manual override (N)/ solenoid and deluxe manual override (T)

SRRB...N/T2...

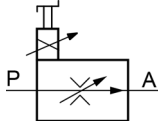

SRRB...N/T2.../01

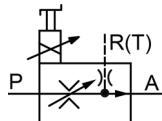

SRRB...N/T2.../15

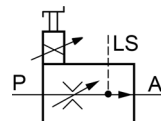

SRRB...N/T2.../16

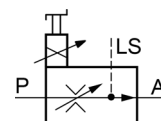

SRRB...T2.../07

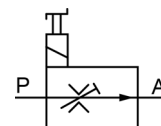

SRRB...T2.../16

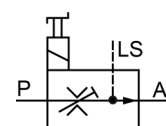

2.1.3 Type of operation: Manual override (H)

SRRB...H2...

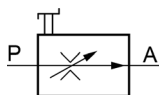

SRRB...H2...-R 1)

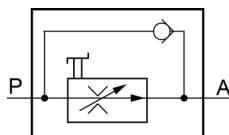

2.2 3-way flow control valves

2.2.1 Type of operation: Solenoid and emergency pin (S)

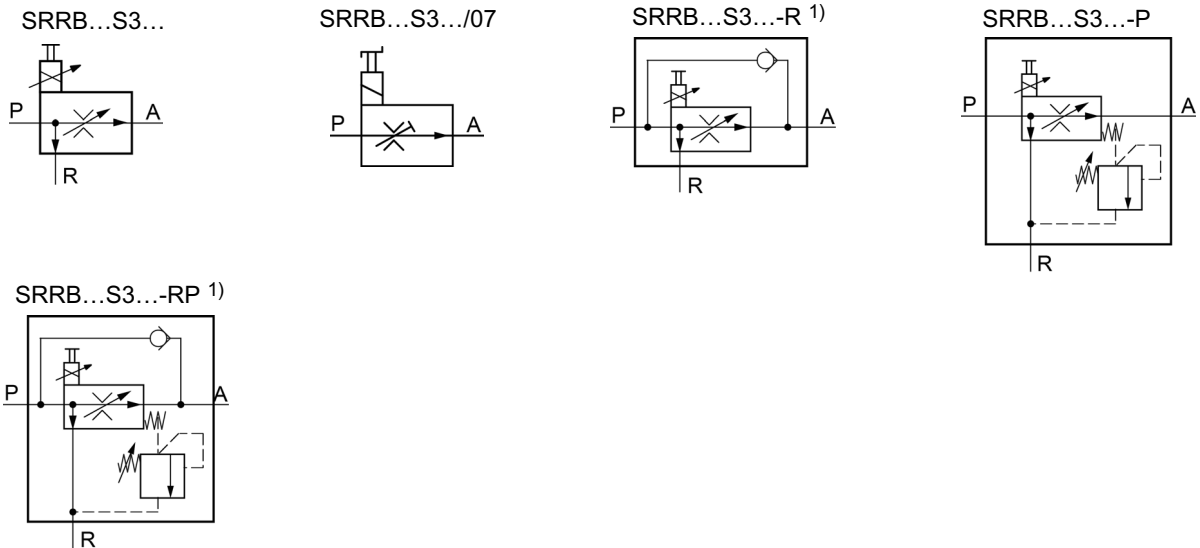

2.2.2 Type of operation: Solenoid and basic manual override (N)/ solenoid and deluxe manual override (T)

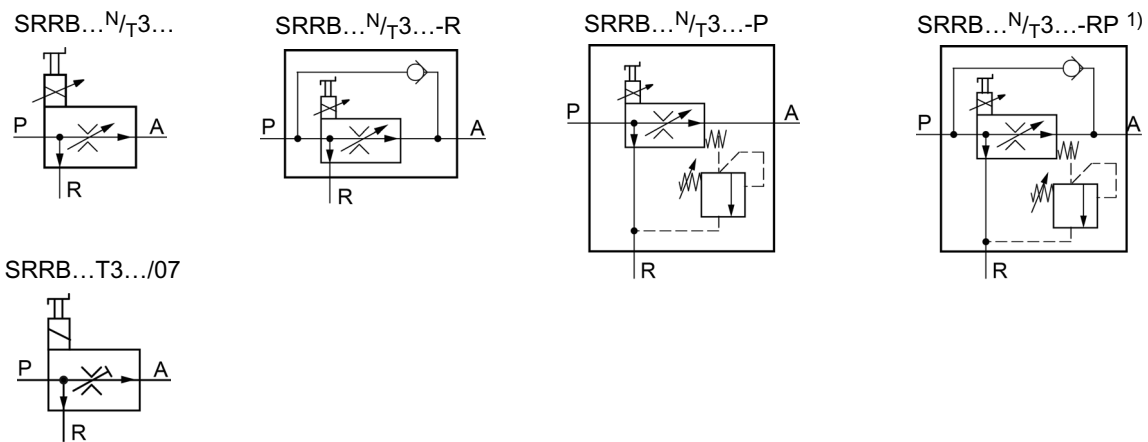

2.2.3 Type of operation: Manual override (H)

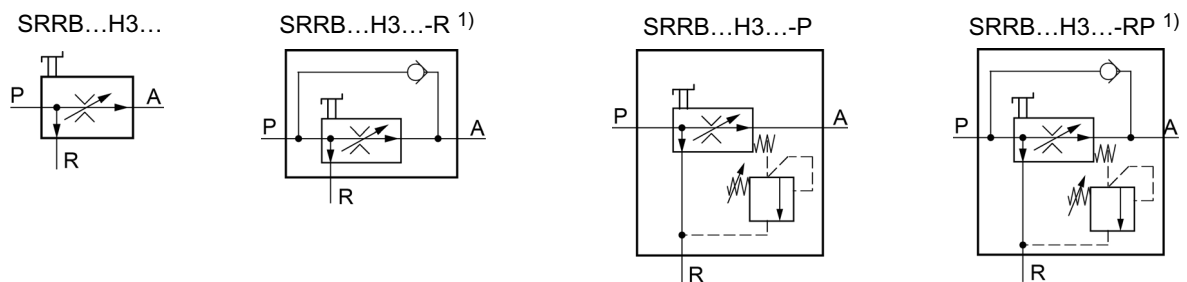

1) Can only be used as a anti - cavitation check valve after consultation with Bucher Hydraulics.

3 Technical data

General characteristics	Unit	Description, value
Design		line mounting
Flow direction		P → A controlled P → R surplus flow discharge (models shown in 2.1 and 2.3 surplus flow can be pressured)
Seals		Viton (FPM)
De-energized position		orifice closed
Mounting attitude		Unrestricted; preferably with coil at bottom (auto. air bleed)
Electrical characteristics	Unit	Description, value
Design		high pressure; wet armature
Supply voltage		12 or 24 from an electronic controller
Power consumption	W	21 at 12 V coil and I _{max.} = 2,3 A 21 at 24 V coil et I _{max.} = 1,15 A
Dither frequency required	Hz	100 (pay attention to I _{max.})
Relative duty cycle		100% at I _{max.}
Protection class (with a properly-fitted plug)		AMP Junior Timer IP65 Deutsch plug IP67 DIN EN 60529
Electrical connection		AMP Junior Timer plug connector (2-pole) Deutsch plug DT04-2P-EP04
Hydraulical characteristics	Unit	Description, value
Constant flow range	l/min	10, 16, 25, 32, 40, 50, 63, 80 ¹⁾
Inlet flow	l/min	max. 100 ¹⁾
Operating pressure	bar	max. 315 ²⁾
Leakage	cm ³ /min	max. 100 at 100 bar ¹⁾
Minimum pressure difference (pressure compensator)	bar	7
Control accuracy (depending on the nominal flow): Load-dependency when under pressure Hysteresis when operated		max. ± 2.5% ³⁾ max. ± 3.5% ³⁾
Fluids		mineral oil to DIN 51524 ⁴⁾
Fluid temperature range	°C	-20 ... +80
Viscosity range	mm ² /s	10 ... 300
Max. admissible level of contamination of the hydraulic fluid		ISO 4406 class 20/18/15

1) Values refer to an oil viscosity of 35 mm²/s (cSt).

2) For higher pressures consult Bucher Hydraulics

3) Values refer to the selected flow range.

4) for other fluids, consult Bucher Hydraulics.

4 Performance graphs

4.1 Q - I characteristics

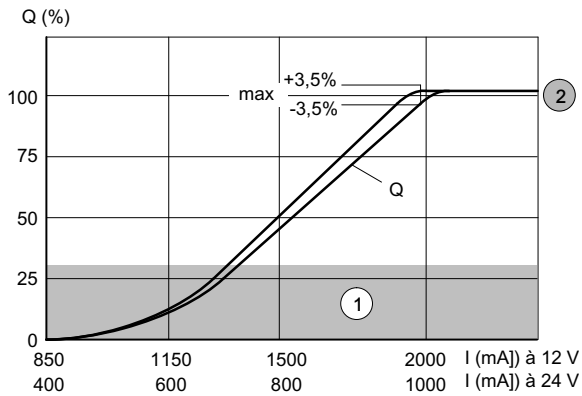

1	Fine control range
2	Q_A - constant flow pressurised

4.2 Variation in flow

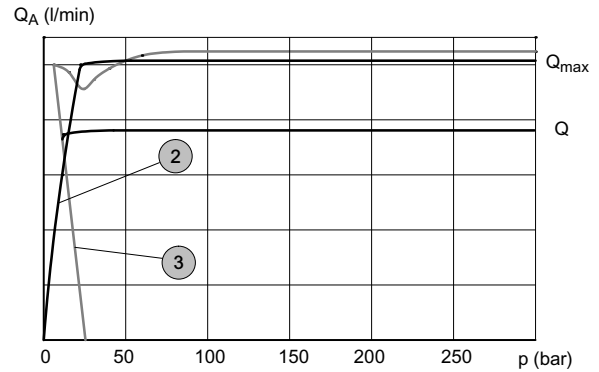

3	Q_A - surplus flow pressurised
---	----------------------------------

4.3 Pressure drop during vented bypass $P \rightarrow R$

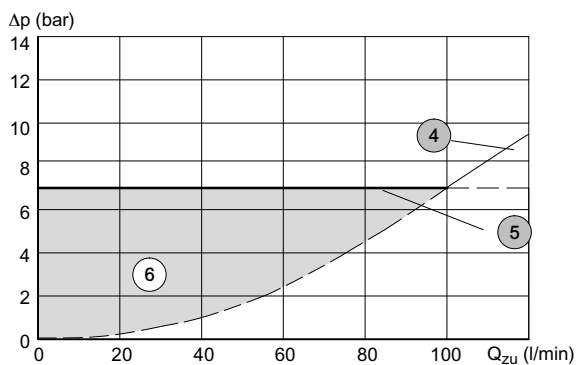

4	Control valve throttling curve
5	Control - Δp - characteristic 7 bar
6	Pressure loss area (the actual pressure-loss characteristic is dependent on the tank pressure at port R)

5 Dimensions

5.1 Flow control valve with manual override

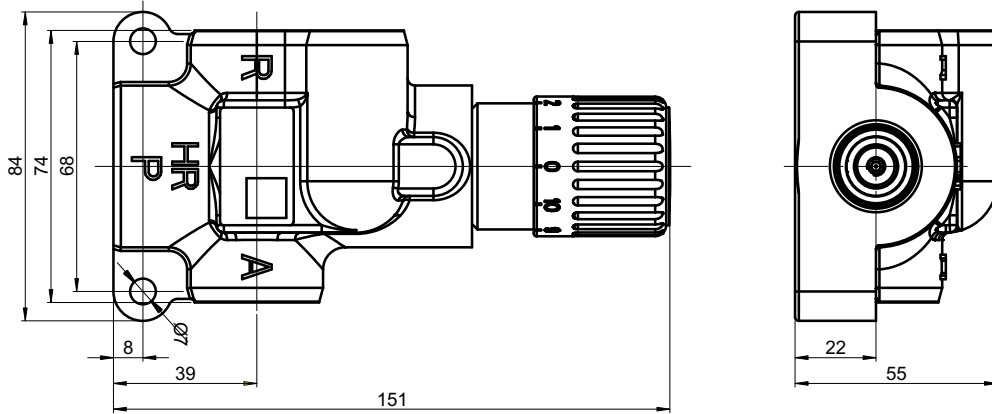

5.2 Flow control valve with proportional solenoid

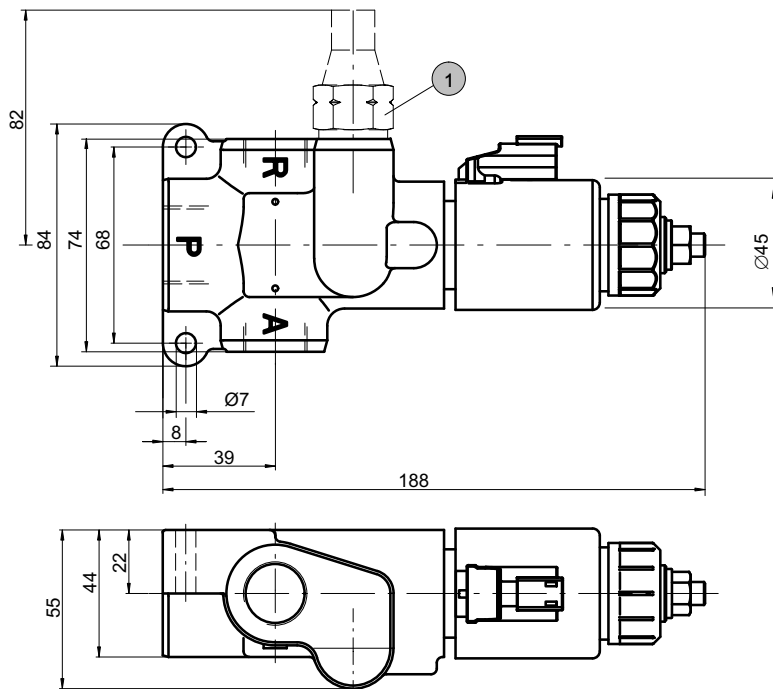

1 Model with pressure relief

5.3 Port threads

Port	SRRB...H.G-...
P	G $\frac{3}{4}$ "
A	G $\frac{1}{2}$ "
R	G $\frac{1}{2}$ "

6 Models

6.1 Manual overrides

6.1.1 Emergency pin, SRR....S..

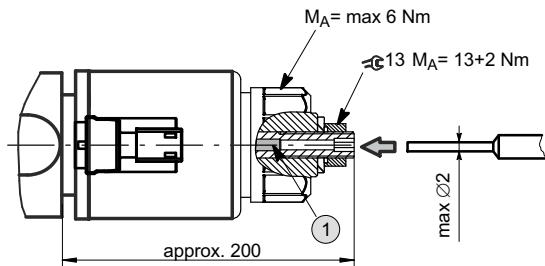

IMPORTANT : By pressing the emergency pin you operate the valve ON/OFF.

1	emergency pin
---	---------------

6.1.2 Basic manual override, SRR....N..

Q_0 to $Q_{max.}$ = approx. 3,5 turns at the rotary knob

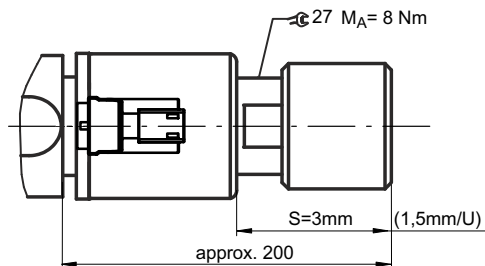

6.1.3 Basic manual override, SRR....T..

Q_0 to $Q_{max.}$ = approx. one turn at the rotary knob

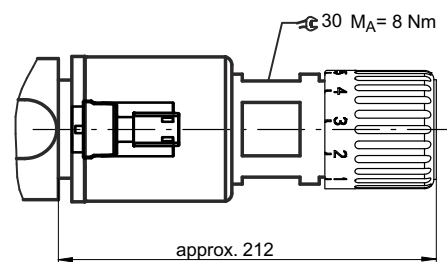

6.2 Plug bases

AMP Junior Timer J	Deutsch plug DT04-2P-EP04 T

7 Ordering code

	S	R	R	B	0	5	0	S	3	G	-	1	T	1	2	-	R	P	/		P=
Flow control valve																					
Pipe mounting																					
Size																					
Constant flow range (10, 16, 25, 32, 40, 50, 63, 80 l/min) e.g. 0...50 l/min					= 050																
Type of operation:	solenoid + emergency pin				= S																
	solenoid + basic manual override				= N																
	solenoid + deluxe manual override				= T																
	manual override				= H																
3-way					= 3																
2-way (for this function please ask Bucher Hydraulics)					= 2																
Port threads																					
Standard:	P: G $\frac{3}{4}$ " / A+R: G $\frac{1}{2}$ "				= G																
(Adapters for pressure port P can be ordered separately, see section 9)																					
Design number (to be inserted by the factory)																					
Plug connector:	AMP Junior Timer				= J																
	Deutsch plug				= T																
Proportional solenoid supply voltage:	DC 12 Volt				= 12																
	DC 24 Volt				= 24																
Bypass check valve A → P					= R ¹⁾																
without					= *																
Pressure relief function (surplus flow cannot be pressurised)					= P ^{2) 3)}																
without					= *																
Options (see section 7.1)																					

1) Can only be used as a anti - cavitation check valve after consultation with Bucher Hydraulics.

2) Not for use with the 2-way flow control valve.

3) Specify the pressure setting in plain text. Pressure setting by steps of 10 bar, between 50 and 310 bar.

7.1 Options

01 = Control flow relief when orifice closed (bypass nozzle, diameter 0.5, between A -> R (B)).

07 = 2 and 3-way flow control valve with ON/OFF solenoid.

15 = LS-port and proportional solenoid.

16 = LS-port and ON/OFF solenoid.

8 Installation information

IMPORTANT!

When mounting the valve, ensure that the body is not subjected to any distorting forces. If necessary use shims to equalise the level of the mounting points. Do not use any pipe fittings with tapered-threads!



To ensure reliable operation, G3/4" fittings with threaded stud ends, length of stud end 16 mm must be used as port P. If required, adapters for G3/4" to G1/2" can be supplied (see section 9).

Bleed all air from the system (if possible, operate the flow control valve several times at no-load)

9 Accessories

9.1 Adapter

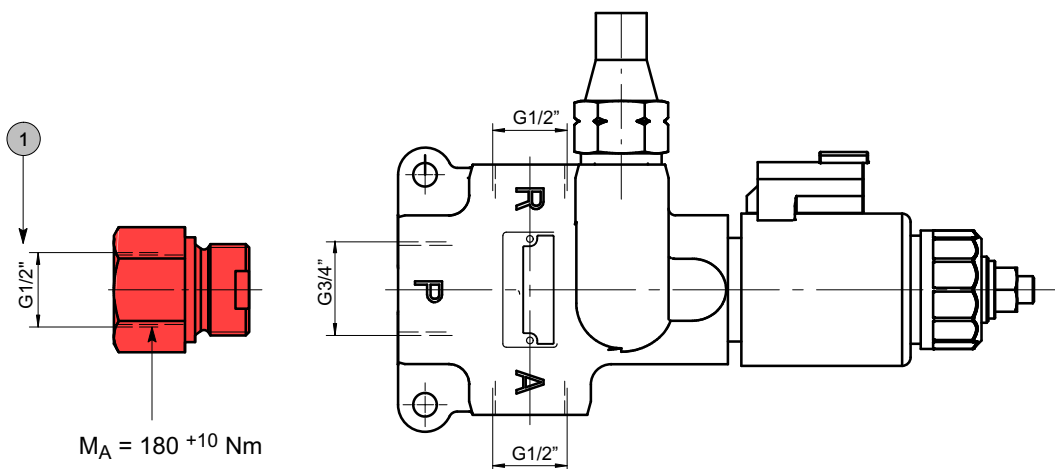

1 Adapter G3/4" -> G1/2"

Model	Description	Part number
Adapter G3/4" -> G1/2"	Adapter with sealing ring profiled sealing ring to DIN 3869 is included with delivery	100235660

info.kl@bucherhydraulics.com

www.bucherhydraulics.com

© 2024 by Bucher Hydraulics GmbH, D-79771 Klettgau

All rights reserved.

Data is provided for the purpose of product description only, and must not be construed as warranted characteristics in the legal sense. The information does not relieve users from the duty of conducting their own evaluations and tests. Because the products are subject to continual improvement, we reserve the right to amend the product specifications contained in this catalogue.

Classification: 430.310.335.310.