

PRESSURE GAUGES



PRESSURE GAUGES
AV - AVD
AT - AY
5-250 Tn.
0-1.000 bar

ACCESSORIES

LARZEP advantages

- High accuracy gauges, $\pm 1.6\%$ full scale.
- Essential for monitoring working pressure or force.
- Available as system pressure gauges or as dual scale gauges to measure load on specific cylinders.
- Glycerine filled gauges.
- Gauge adaptor AZ1502 for AV10006. For all other gauges use AZ1501 gauge adaptor.

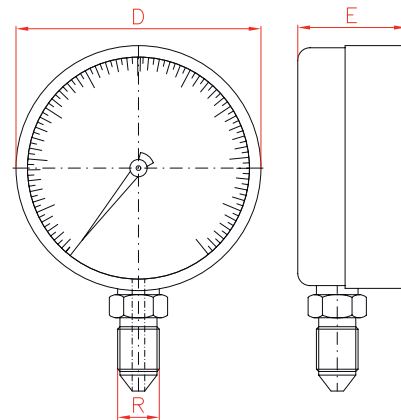

NOTE: Do not exceed the 70% of the nominal capacity of the gauge.



Digital pressure gauge:
Reference: AVD07008.
Thread: 1/4"-BSP.
Gauge adaptor: AZ1507.

Used with	Model	Type		Scale	D	E	R	Gauge Adaptor
	LARZEP	Tn	kg/cm ²		mm	mm		
All Cylinders	AV10006	-	700	50	68	31	1/4"-NPT	AZ1502
	AV10008	-	700	20	80	35	3/8"-BSP	AZ1501
	AV10010	-	700	10	100	35	3/8"-BSP	AZ1501
Cylinders	AT00410	5 / 10	700	-	100	35	3/8"-BSP	AZ1501
	AT03010	30 / 50	700	-	100	35	3/8"-BSP	AZ1501
	AT07510	75 / 100	700	-	100	35	3/8"-BSP	AZ1501
	AT15010	150 / 200	700	-	100	35	3/8"-BSP	AZ1501
Press 10 Tn	AY01008	10	-	0,5	80	35	3/8"-BSP	AZ1501
Press 20 Tn	AT01610	16 / 23	700	-	100	35	3/8"-BSP	AZ1501
Press 30 Tn	AY03008	30	-	2	80	35	3/8"-BSP	AZ1501
Press 60 Tn	AY06010	60	-	2	100	35	3/8"-BSP	AZ1501
Press 120 Tn	AY12010	120	-	4	100	35	3/8"-BSP	AZ1501
Press 250 Tn	AY25010	250	-	5	100	35	3/8"-BSP	AZ1501