



WAWA

Maintenance free welded **Membrane Accumulators**

Construction: carbon steel body Capacity: 0,05÷4 litres Pressure: up to 350 bar



INDEX

OPERATING PRINCIPLE	3
USE SECTORS	3
APPLICATIONS	3
ADVANTAGES	3
HYDRAULIC SYMBOL	3
TECHNICAL SPECIFICATIONS	4
TECHNICAL DATA	4
COMPATIBILITY OF MEMBRANES - TEMPERATURE – FLUID	5
SIZING	5
CERTIFICATIONS	6
ORDERING CODE	7
DIMENSIONS	8
ACCESSORIES	9
SPARE PARTS	10
TRANSPORT	10
COMMISSIONING AND MAINTENANCE	10





Construction: carbon steel body

Capacity: 0,05 ÷ 4 litres

Pressure: up to 350 bar



OPERATING PRINCIPLE

One of the main tasks of the hydraulic accumulators is to accumulate a certain quantity of fluid under pressure from a hydraulic system and return all or part of it to the system when required: for this reason they are considered pressure vessels and must be sized for the maximum operating pressure, taking into account the acceptance standards applicable in the country of installation.

Accumulators with separation element between the fluid side and the gas side, that are normally pre-loaded with nitrogen, are used in most hydraulic systems.

Depending on the type of separation element, the accumulator takes its name: the WAs are membrane accumulators.

The maintenance free membrane accumulators type WA cannot be repaired, since they have been specially designed for high production, low cost applications, for which it is more practical and convenient to replace rather than repair the equipment.

These accumulators consist of two cups made of high-strength steel and welded with electron beam.

The U-shaped membrane separates the gas side from the fluid side. Membranes are available in nitrile rubber NBR, epichlorohydrin (ECO) and nitrile rubber for low temperatures – 40 °C. A suitable button made of high-resistance material closes the hole on the fluid side when the accumulator is precharged, to avoid the extrusion of the membrane.

The gas valve is available in a standard version M28x1.5 with allen locking screw and sealing washer in rubber-metal (for the pre-charge you must use the precharge and control equipment DP100), in the (special) version with small valve 5/8" UNF (for the pre-charge you must use the precharge and control equipment DP200), while in the version with factory fixed precharge and electrowelded closing plug the precharge pressure value cannot be controlled and/or modified.

The fluid coupling is available in the standard threaded connections listed in the table, in male or female versions and in the version with double thread for a quick, safe, inexpensive anchoring via the external thread and fastening ring nut (optional, see chapter 14), as well as a suitable female connection.

Compared with others, these accumulators have a high energy yield, as they have a higher energy density (energy content/mass): this feature is due to the spherical shape of the accumulator body. WA-type membrane accumulators can be installed in any position.



USE SECTORS

The maintenance free membrane accumulators type WA are used for the most varied applications in the industrial, machine tools, mobile and agriculture industries.



APPLICATIONS

- Energy reserve in systems with intermittent operation for power reduction of the pump
- Energy reserve for emergencies, such as in case of failure of the motor-pump assembly or power outage
- Compensation for losses due to leakage
- Pressure compensator (balance)
- Vibration damping in the case of periodic oscillations
- Volume compensation in the event of changes in pressure and temperature
- Hydraulic spring for the suspensions on vehicles
- Shock absorption in case of mechanical impact.

ADVANTAGES

- Compact product
- Quick and easy installation
- High life cycle
- High energy efficiency
- High compression ratio, max 8 : 1
- Fast response time (less than 25 ms)
- Operation also with low lubricating power fluids
- Good tolerance to dirt (contaminants present in the fluid)
- Reduced weight
- Low cost

Maintenance free welded membrane accumulators/dampeners

TECHNICAL SPECIFICATIONS

Maximum pressure	100 - 140 - 210 - 250 - 280 - 300 - 350 bars	
Nominal capacity	0,05 - 0,16 - 0,35 - 0,5 - 0,75 - 1 - 1,4 - 2 - 3 - 3,5 - 4 litres	
Materials	Body	Painted carbon steel RAL 9004 (opaque) (resistance to salt spray 250 hours)
		on request: resistance to salt spray 500 hours
		on request: AISI 316L
	Membrane	NBR (Perbunan)
		ECO (Epichlorohydrin)
		NBR -40 °C
	Precharge valve	M28x1,5
Electrowelded plug with factory fixed precharge		
5/8"UNF valve (on request)		
Operating temperature with membrane	NBR: -15 ÷ +80°C	
	ECO: -30 ÷ +120 °C	
	NBR -40: -40 ÷ +70 °C	
Precharge at 20 °C	Pressure value on request ($\pm 5\%$ with minimum ± 3 bar) with Nitrogen: N $\geq 99,9\%$ volume, O ₂ ≤ 50 Vpm and H ₂ O ≤ 30 Vpm	

TECHNICAL DATA

Type	Rated volume [lt]	Effective volume [lt]	Max pressure* (in carbon steel) [bar]	Max dynamic Delta P P ₂ - P ₁ [bar]	Max compress. ratio P ₂ :P ₀	Max flow ** [l/min]	Ped category (for liquids in Group 2)	Weight [kg]
WA 0,05	0,05	0,07	210	120	6:1	10	Art.3 Par.3	0,5
WA 0,16	0,16	0,17	210 250	120	6:1	10	Art.3 Par.3	0,9
WA 0,35	0,35	0,35	100	100	6:1	40	Art.3 Par.3	1
		0,41	210 250	140				1,8
WA 0,5	0,5	0,58	100	140	8:1	40	Art.3 Par.3	1,6
			140					2,4
			210 300					2,8
WA 0,75	0,75	0,77	100	120	6:1	40	Art.3 Par.3	2,0
			140					3,2
			210	150	4:1			3,4
			250		8:1			3,2
			280		4:1			5,2
350	6:1	5,2						
WA 1	1	1,00	210	140	4:1	40	Art.3 Par.3	4,0
			250	150	8:1			4,8
			280	140	4:1			4,5
WA 1,4	1,4	1,42	100	80	6:1	80	Cat:II	3,6
			140					5,5
			250	140	6:1			8,5
WA 2	2	2,00	140	60	4:1	80	Cat:II	6
			250	140				6,6
			210	140				8,1
WA 3	3	3,15	210	140	4:1	120	Cat:II	10,8
			250					14,6
			350	180			Cat:III	14,6
WA 3,5	3,5	3,55	210	140	4:1	120	Cat:II	8,9
			250					12,1
			350				Cat:III	16,6
WA 4	4	4,00	210	140	4:1	120	Cat:II	9,9
			250					13,4

* Maximum pressure calculated according to EN 14359 (for the pressure values in agreement with other standards, please contact SAIP)

** Flow rate measured using mineral oil with a viscosity of 36 cSt at 50 °C and $\Delta P = 5$ bar

*** Maximum differential pressure permissible (pressure difference between the maximum operating pressure P₂ and the minimum operating pressure P₁) in order to have an infinite life cycle (greater than 2.000.000 cycles).



Construction: carbon steel body
Capacity: 0,05 ÷ 4 litres
Pressure: up to 350 bar



COMPATIBILITY OF MEMBRANES / TEMPERATURE / FLUID

1	Nitrile rubber NBR	-15 ÷ +80 °C	Suitable for aliphatic hydrocarbons (propane, butane, gasoline, oils, mineral greases, diesel fuel, fuel oil, kerosene), mineral greases and oils, fluids HFA - HFB - HFC, many diluted acids, saline solutions, water, glycol water.
1C	Nitrile rubber for low temperatures NBR	-40 ÷ +70 °C	Fluids compatibility as for standard nitrile + various types of freon. (Has lower content of acrylonitrile than the standard and is therefore more suitable for work at low temperatures, but the chemical resistance to the different liquids is slightly lower).
8	Epichlorohydrin ECO	-30 ÷ +120 °C	Suitable for mineral oils and greases, aliphatic hydrocarbons (propane, butane and gasoline), silicone oils and greases, water at room temperature, low gas permeability, good resistance to ozone, ageing and weathering.

For the use of other fluids and temperatures, please contact SAIP

SIZING

For an accumulator sizing, various factors are to be considered, associated with the type of accumulator itself, operating pressure, relevant precharge pressure, necessary volumes and operating temperatures.

Status

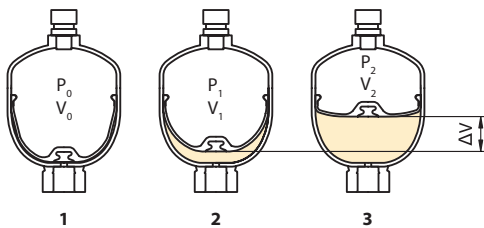

1) P_0 = (nitrogen precharge pressure) and V_0 = (gas effective volume) correspond to precharge conditions. Hydraulic pressure value is lower than precharge value, i.e. the membrane expansion is maximum and there is no fluid inside the accumulator. A special button closes the hole on the liquid side to prevent membrane extrusion.

2) P_1 = (minimum operating pressure) and V_1 = (gas volume at pressure P_1) correspond to minimum pressure conditions, i.e. since the fluid pressure is slightly higher than precharge pressure, it remains inside the accumulator, to prevent that - at each cycle - the membrane and the plate collide against the accumulator internal surface.

3) P_2 = (maximum operating pressure) and V_2 = (gas volume at pressure P_2) correspond to maximum pressure conditions, i.e. membrane has reached its maximum shrinkage, resulting in maximum liquid accumulation.

ΔV = rated volume delivered/absorbed =

$$V_{1, \text{gas}} - V_{2, \text{gas}} = V_{2, \text{fluid}} - V_{1, \text{fluid}}$$

Precharge pressure

Value of precharge pressure varies depending on accumulator application:

- A) Energy accumulation, emergency function, hydraulic spring, force compensator, leakage compensator, volume compensator: in these applications, precharge pressure is usually $P_0 = 0.9 \div 0.95 \times P_1$ (at maximum operating temperature). Compression ratio $P_2 : P_0$ is also to be met, being lower than specified in paragraph Technical data (4:1.6:1, max 8:1)
- B) Pulsation damper
 $P_0 = 0.7 \div 0.9 \times P$ (operating pressure)
Referred to maximum operating pressure.
- C) Absorber of water hammers
 $P_0 = 0.9 \div 0.95 \times P$ (operating pressure)
Referred to maximum operating pressure.

Temperature changes

Operating temperature change can strongly affect the accumulator precharge pressure. When temperature increases, the precharge pressure increases; on the contrary, when temperature decreases, the precharge pressure decreases. To better use the accumulator, precharge pressure needs to be calculated considering temperature changes during operation.

$$P_0(T_{20}) = P_0(T_x) \times \frac{20 + 273}{T_x + 273}$$

$P_0(T_x)$ = pressure at temperature measured T_x
 $P_0(T_{20})$ = nitrogen pressure P_0 at 20 °C

Sizing with isothermal transfer

Example: leakage compensation, volume compensation. Calculation in isothermal transfer only applies when both accumulation and discharge occur in a long time (more than 10 minutes), so that an efficient heat exchange is allowed and nitrogen temperature is kept almost constant. Accumulator volume:

$$V_0 = \frac{\Delta V}{\frac{P_0}{P_1} - \frac{P_0}{P_2}}$$

V_0 and ΔV in litres

P_0 and P_1 and P_2 in absolute bars (bar(a) = bar(g) +1)

Accumulator yield:

$$\Delta V = V_0 \times \left(\frac{P_0}{P_1} - \frac{P_0}{P_2} \right)$$

Dimensionamento con trasformazione adiabatica

Example: energy accumulation, hydraulic spring, suspensions, force compensator.

Calculation in adiabatic transfer only applies when accumulation and discharge both occur in a short time, so that no heat exchange is allowed between gas and environment. (When quickly compressed, nitrogen increases temperature, on the contrary temperature decreases when released).

Accumulator volume:

$$V_0 = \frac{\Delta V}{\left(\frac{P_0}{P_1} \right)^{\frac{1}{1.4}} - \left(\frac{P_0}{P_2} \right)^{\frac{1}{1.4}}}$$

V_0 and ΔV in litres

P_0 and P_1 and P_2 in absolute bars (bar(a) = bar(g) +1)

Accumulator yield:

$$\Delta V = V_0 \times \left[\left(\frac{P_0}{P_1} \right)^{\frac{1}{1.4}} - \left(\frac{P_0}{P_2} \right)^{\frac{1}{1.4}} \right]$$

Sizing with polytropic transfer

Example: emergency, safety.

Calculation in polytropic transformation only applies when accumulation is slow (isothermal) and discharge is quick (adiabatic).

Accumulator volume:

$$V_0 = \frac{\Delta V \times \frac{P_2}{P_0}}{\left(\frac{P_2}{P_1} \right)^{\frac{1}{1.4}} - 1}$$

V_0 and ΔV in litres

P_0 and P_1 and P_2 P_2 in absolute bars (bar(a) = bar(g) +1)

Accumulator yield:

$$\Delta V = V_0 \times P_0 \times \frac{\left(\frac{P_2}{P_1} \right)^{\frac{1}{1.4}} - 1}{P_2}$$

Using the formulas above, accumulator volume can be calculated with good degree of approximation and/or the volume obtained depending on accumulator dimension specified.

For other usages and/or for a more accurate calculation, considering temperature changes, real charge and discharge times, real and not ideal gas usage, SAIP SIZAC calculation software can be used as available on site www.saip.it or contacting directly SAIP technical service.

CERTIFICATIONS

All hydraulic accumulators are pressure vessels and are subject to the national legislation and directives applicable in the country of installation.

The accumulators type WA are manufactured in accordance with the European directive PED (97/23); for capacities lower than or equal to 1 litre CE marking is not required, while for higher capacities, in addition to the CE marking, each accumulator must be accompanied by the declaration of conformity and by the operation and maintenance manual.

The Technical data table indicates the category related to the use with not dangerous fluids (group 2), as a function of the product: volume by pressure.

For use with hazardous fluids (group 1), please contact SAIP. In compliance with the European Directive PED (97/23/CE), documentation includes the declaration of conformity and the use and maintenance manual.

Accumulators can also be supplied according to directive ATEX 94/9/CE (annex VIII) and harmonized standards EN 13463-1 concerning non electrical products to be used in potentially explosive atmosphere environments and not included in classification ATEX CE II2GcT4.

SAIP also provides for other tests and certifications for countries where CE certification is not recognized.

- ASME-"U"- Stamp for USA (National Board), Canada (CRN), South Africa, etc.
- ML (ex SQL) for China.
- Australian Pressure Vessel standard AS1210-1997 for Australia.
- GOST-R for Russia, Ukraine, Kazakhstan, etc.
- Dossier RTN - Rostechndzorf for Ukraine, Russia, Kazakhstan, etc.
- DDP passport for Algeria, Tunisia etc.
- DOSH for Malaysia

Anyway, for other countries or applications requiring for a specific test, accumulators are manufactured in compliance with the European Directive, but supplied without CE mark and with factory test or according to the standard applied.

Other certifications, such as for naval sector, can be required upon order.



Construction: carbon steel body

Capacity: 0,05 ÷ 4 litres

Pressure: up to 350 bar



ORDERING CODE

WA		2		1,4		8		0		G5		A		250			
Accumulator type		Gas valve		Nominal capacity		Membrane material		Body material		Fluid side connection		Calculation code and testing/certification		Maximum pressure			
WA	membrane, welded with electron beam	2	M28x1.5 gas valve	litres		1	standard NBR nitrile with button in plastic material	O	carbon steel	A2	capacity	threading	A	According to the relative capacity and with calculation code EN14359			
				0,05	0,05									litres	bar		
				0,16	0,16									210	0,05	210	
		4	Plug in welded carbon steel	0,35	0,35				X	316L stainless steel (upon request)	M8	0,05	M18x1.5 female		210	0,16	210
				0,5	0,5									250		250	
				0,75	0,75									100		100	
		1	5/8 UNF galvanized valve (on request)	1	1	1C	Nitrile for low temperatures with plastic button				G4		1/2" gas (ISO228) female	K	210		210
				1,4	1,4									210	0,35	210	
				2	2									210		250	
				3	3									250		250	
				3,5	3,5									100		100	
				4	4	8	Epichlorohydrin ECO with plastic button				M8		M18x1.5 female		140	0,5	140
							Other compounds on request. Membrane with stainless steel button on request				G4		1/2" gas (ISO228) female	L	210		210
														300		300	
														100		100	
											0,16 ÷ 0,75	1/2" gas (ISO228) female + spot-facing DIN3852	J	140		140	
												1/2" gas (ISO228) female + outer threading M33x1.5		210	0,75	210	
														250		250	
														280		280	
														280		280	
														350		350	
														210	1	210	
														250		250	
														280		280	
														100		100	
														140	1,4	140	
														250		250	
														350		350	
														140		140	
														250	2	250	
														210		210	
														250	3	250	
														350		350	
														210		210	
														250	3,5	250	
														350		350	
														210		210	
														250	4	250	
														250		250	
														With other calculation codes, the maximum pressures may change			
														Other connections on request			

Note: in orders, specify precharge value referred to 20 °C temperature in addition to the complete code.

Maintenance free welded membrane accumulators/dampeners

DIMENSIONS for pressures up to 300 bar

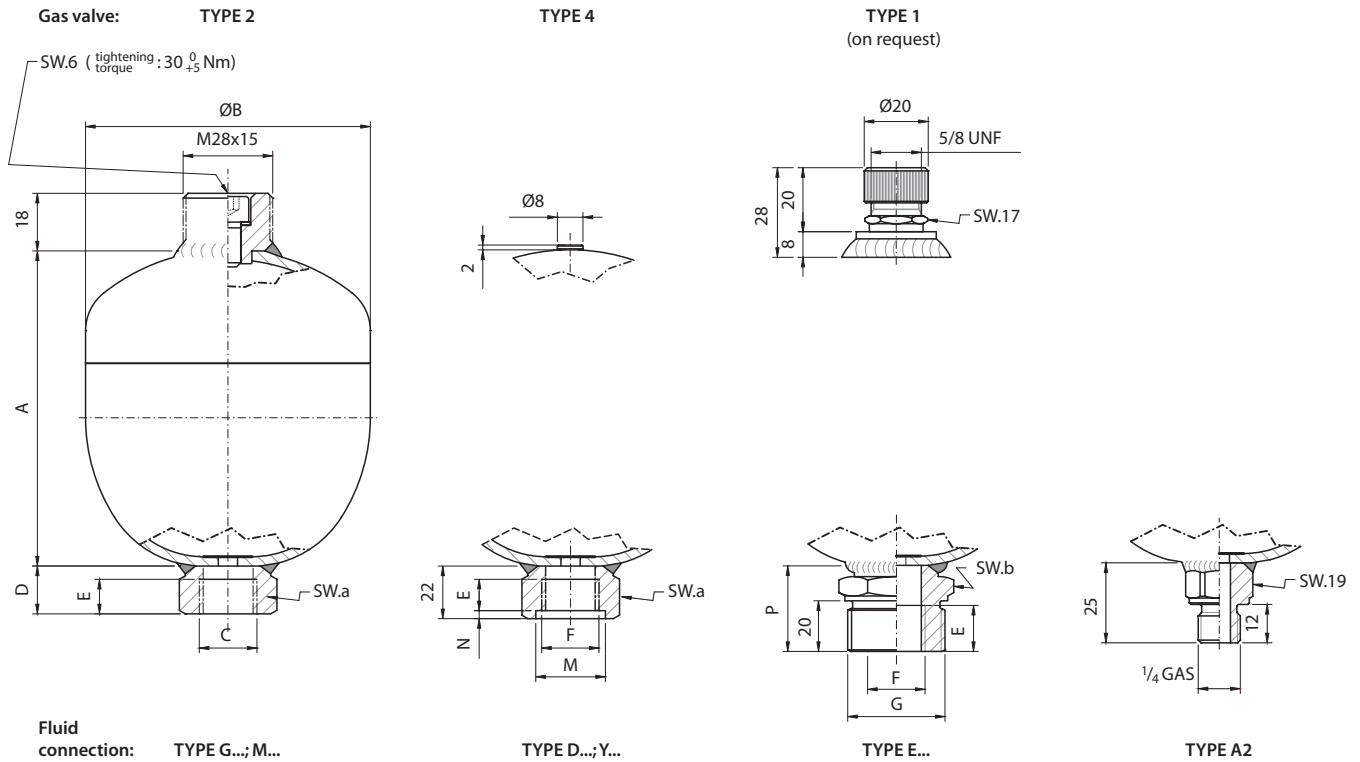

Type	Pressure [bar]	Gas valve			A [mm] (± 2)	ØB [mm] (+0/-1)	C		D [mm]	E [mm]	F	G	M	N	P	SW a	SW b
		Type 1	Type 2	Type 4			M8	G....									
WA 0,05	210	5/8"UNF	M28X1,5	Welded plug	67	55,5	—	1/2"Gas	20	15	—	—	—	—	30	—	
	210	5/8"UNF	M28X1,5	Welded plug	86	70	M18X1,5	1/2"Gas	20	15	1/2"Gas	M33x1,5	27	2,5	38	30	41
WA 0,35	100	5/8"UNF	M28X1,5	Welded plug	97	90	M18X1,5	1/2"Gas	20	15	1/2"Gas	M33x1,5	27	2,5	38	30	41
	210				112	96											
	250				112	96											
WA 0,5	100	5/8"UNF	M28X1,5	Welded plug	122	101	M18X1,5	1/2"Gas	20	15	1/2"Gas	M33x1,5	27	2,5	38	30	41
	140				122	101											
	210				126	105											
	300				130	109											
WA 0,75	100	5/8"UNF	M28X1,5	Welded plug	139	109	M18X1,5	1/2"Gas	20	15	1/2"Gas	M33x1,5	27	2,5	38	30	41
	140				139	109											
	210				135	117											
	250				133	122											
WA 1	210	5/8"UNF	M28X1,5	Welded plug	171	117	—	1/2"Gas 3/4"Gas	20 24	15 16	1/2"Gas —	M33x1,5 —	27 34	2,5 1	38 —	30 41	41 —
	250				146	136											
	280				171	117											
WA 1,4	100	5/8"UNF	M28X1,5	Welded plug	153	142	—	1/2"Gas 3/4"Gas	20 24	15 16	1/2"Gas —	M33x1,5 —	27 34	2,5 1	38 —	30 41	41 —
	140				153	142											
	250				154	153											
WA 2	140	5/8"UNF	M28X1,5	Welded plug	200	142	—	1/2"Gas 3/4"Gas	20 24	15 16	1/2"Gas —	M33x1,5 —	27 34	2,5 1	38 —	30 41	41 —
	250				193	153											
WA 3	210	5/8"UNF	M28X1,5	Welded plug	235	170	—	3/4"Gas	24	16	3/4"Gas	M45x1,5	34	1	42	41	46
	250				239	174											
WA 3,5	210	5/8"UNF	M28X1,5	Welded plug	262	170	—	3/4"Gas	24	16	3/4"Gas	M45x1,5	34	1	42	41	46
	250				266	174											
WA 4	210	5/8"UNF	M28X1,5	Welded plug	288	170	—	3/4"Gas	24	16	3/4"Gas	M45x1,5	34	1	42	41	46
	250				292	174											



Construction: carbon steel body

Capacity: 0,05 ÷ 4 litres

Pressure: up to 350 bar



DIMENSIONS for pressure at 350 bar

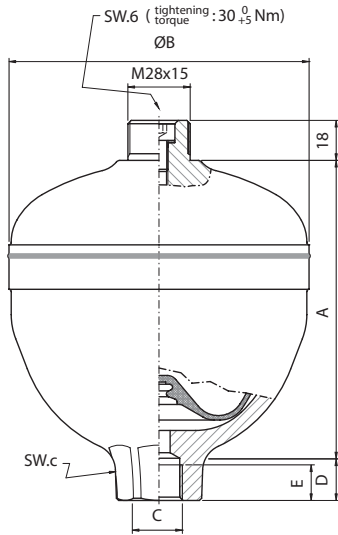

Type	Pressure [bar]	Gas valve Type 2	A [mm] (±2)	ØB [mm] (+0/-1)	C G....	D [mm]		E [mm]		F E.....	G M33x1,5	P [mm]	Q [mm]	SW b [mm]
WA 0,75	350	M28X1,5	133	134	½"Gas	20	15	½"Gas	M33x1,5	38	18	41		
WA 1,4	350	M28X1,5	161	164	½"Gas ¾"Gas	20	15	½"Gas	M33x1,5	38	18	41		
						24	16							
WA 3	350	M28X1,5	224	182	¾"Gas	24	16	¾"Gas	M45x1,5	42	20	55		
WA 3,5	350	M28X1,5	264	182	¾"Gas	24	16	¾"Gas	M45x1,5	42	20	55		

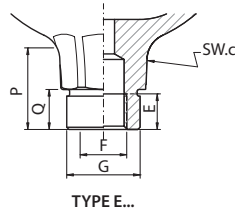

Fluid connection: TYPE G...

ACCESSORIES

Fastening nut

They are used to simply and safely fasten accumulators by outer threading type E1 (M33x1.5) or E7 (M45x1.5) on fluid side attachment.

Accumulators equipped with gas valve type 2 can be fastened by M28x1.5 threading, by using the relevant ring nut in the table. Nuts shown below are made of zinc plated white carbon steel in compliance with directive 2002/95/CE (RoHS) with excellent corrosion resistance.

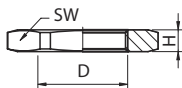

Type	D	SW		H
		[mm]	[mm]	
DADORM2-OZ28	M28 x 1,5	41	7	
DADORE1-OZ33	M33 x 1,5	50	7	
DADORE7-OZ45	M45 x 1,5	70	7	

Mounting collars

SAIP mounting collars type CFOZ_LF_ can be used to safely fasten various types of WA accumulators and ensure an independent and non-rigid mounting on plants.

The rubber insert is used to reduce vibration transmission, compensate manufacturing tolerances and release external stresses from connection.

This type of collar consists of a two-piece frame to make installation easier, increase modularity and stability depending on needs and spaces available. Base plate is made of zinc plated white carbon steel in compliance with directive 2002/95/CE (RoHS) with excellent corrosion resistance.

The belt fastening the accumulator at the base also consists of carbon steel with the same characteristics as its base and keeps the accumulator body isolated from a nitrile rubber NBR belt a 80 Shore A.

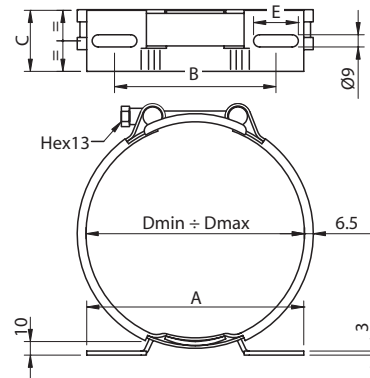

Type	Description							Weight [kg]	To be used on WA
	D _{min}	D _{max}	A	B	C	E			
	[mm]	[mm]	[mm] +/-1	[mm] +/-0,5	[mm]	[mm]			
CFOZ72LF120	67	72	124	94	45	22	0,3	WA0,16	
CFOZ96LF120	90	96	124	94	45	22	0,3	WA0,35	
CFOZ96LF160			164	123	45	33	0,4		
CFOZ102LF160	97	102	164	123	45	33	0,4	WA0,5 100/140	
CFOZ111LF160	103	111	164	123	45	33	0,4	WA0,5 210/300 WA0,75 100/140	
CFOZ120LF160	112	120	164	123	45	33	0,4	WA0,75 210/280 WA1 210/280	
CFOZ128LF160	121	128	164	123	45	33	0,4	WA0,75 250	
CFOZ137LF160	129	137	164	123	45	33	0,4	WA1 250 WA0,75 350	
CFOZ146LF160	138	146	164	123	45	33	0,4	WA1,4 100/140 WA2 140	
CFOZ146LF210			214	173	50	33	0,5		
CFOZ159LF160	147	159	164	123	45	33	0,4	WA1,4 250 WA2 250	
CFOZ159LF210			214	173	50	33	0,5		
CFOZ172LF160	160	174	164	123	45	33	0,5	WA1,4 350 WA3/3,5/4 210/250	
CFOZ172LF210			214	173	50	33	0,5		
CFOZ185LF160	173	185	164	123	45	33	0,6	WA3/3,5 350	
CFOZ185LF210			214	173	50	33	0,6		

For further support and fastening accessories, see catalogue: DISFI

For precharge appliances, see catalogue: DISPR

For other accessories, contact SAIP srl saip@saip.it

SPARE PARTS

Gas valve for WA type 2 (M28x1.5):
VITCM816T-012B Fastening screw
GUAUSITM8-1 Sealing washer

TRANSPORT

The maintenance free membrane accumulators type WA (up to the capacity of 1.4 litres) are hydraulic or pneumatic pressure vessels (UN 3164). They do not fall within the provisions of the ADR for road transport as "these accumulators are not subject to the requirements of class 2 according to the Special Provision 283 ADR" and are not subject to the IATA regulations for air transport, because they comply with the Special Provision IATA A114, since:

- the burst pressure is 4 times the precharge pressure at 20° C for capacities not exceeding 0.5 litres and 5 times higher than the precharge pressure when the capacity is greater than 0.5 litres.
- the accumulators of the WA series are constructed with materials that do not fragment in case of breakage
- the accumulators of the WA series are constructed in accordance with applicable regulations and according to an ISO 9001 quality system
- the prototype of the above-mentioned accumulators have been submitted to fire exposure test to demonstrate that accumulator is effectively protected against any internal overpressure by a fuse element and/or a decompression device, so that it cannot explode and fragment or be projected, provided that capacity does not exceed 1.6 litres and precharge pressure is not higher than 280 bars when capacity value (in litres) multiplied by precharge pressure does not exceed 80 (i.e. 0.5-litre volume and 160-bar maximum precharge pressure or 1-litre volume and 80-bar maximum pressure or 1.4-litre volume and 50-bar maximum precharge pressure or 0.35-litre volume and 228-bar maximum precharge pressure).

For using and transporting pressurized containers of nitrogen, comply with all relevant national and international regulations.

COMMISSIONING AND MAINTENANCE

Supply conditions

When delivered, WA-type membrane accumulators are precharged with nitrogen at pressure required on order.

Anyway, precharge value is marked on accumulator body.

Depending on dimension and quantity ordered, these accumulators are shipped in cardboard boxes or cardboard boxes on pallets or, on request, in wooden boxes.

When accumulators are delivered, the relevant certificates are issued, together with all documents required on order.

Handling

The original packaging is suitable for handling and storage. If necessary, suitable lifting equipment is to be used for handling. Anyway, always protect the packaging from shocks and handle with care.

Storage

When in warehouse, keep the product in its original packaging, away from heat sources and open flames. Recommended storage temperature must be always between +10 ÷ +40 °C.

After six-month storage, precharge pressure must be taken to 2 bars (in versions where allowed); also ensure that lubrication fluid inside is compatible with bag material.

Anyway, it is recommended not to exceed four-year storage.

Mark on accumulator body

With reference to PED 97/23/EC classification, article 3, paragraph 3 and/or risk categories I to IV, according to volume and maximum operating pressure, accumulator shows the following marks:

- manufacturer's name
- product identification code
- manufacturing month and year
- number of castings of upper and lower cups
- maximum pressure in bar
- maximum and minimum temperature in degree Celsius
- volume in litres
- CE mark (when volume exceeds 1 litre) and identification number of the certifying organism (when accumulator is within the second, third and fourth PED category)
- precharge pressure in bar.

It is strictly forbidden

- to weld, nail, or fasten any accumulator component, unless expressly required
- to permanently engrave accumulator body surface and/or perform other operations possibly affecting or modifying accumulator mechanical characteristics
- to use accumulator like a structural element: do not submit it to stresses or charges
- to modify nameplate data and/or accumulator without previous manufacturer's authorization
- to use a fluid belonging to Group 1 (dangerous) with appliances designed and manufactured for fluids belonging to Group 2.

Installation

Before installation, visually inspect accumulator to ensure it has not been damaged during transport/handling.

Ensure that type required corresponds to mark.

WA-type accumulator can be installed in any position, with nameplate data marking clearly visible.

It is recommended to use accumulator with suitable safety valve installed on circuit. This device protects both user and appliance against any damages arising from pressure peaks.

Install so that no abnormal force burdens accumulator connection and pipes directly or indirectly connected with accumulator; to prevent the transmission of any vibration, it is recommended to use support and fastening components shown in paragraph 14 or catalogue: DISFI).

Ensure that accumulator is connected with hydraulic circuit by suitable connection devices.

Ensure that fluid is compatible with membrane elastomer.

Ensure that accumulator maximum pressure allowed is equal to or higher than hydraulic circuit pressure and temperature is kept within the range specified, during operation.

Ensure that fluid does not contain any contaminant and/or abrasive substance.



Construction: carbon steel body

Capacity: 0,05 ÷ 4 litres

Pressure: up to 350 bar



Nitrogen precharge

When delivered, membrane accumulators are usually precharged with pressurized nitrogen. Gas precharge can be controlled and/or adjusted before or after the accumulator installation in hydraulic circuit if the type installed has a gas valve and is not the type with welded plug and factory fixed precharge.

The precharge pressure should be checked before the start-up of the circuit.

Nitrogen (chemical symbol N₂) is gaseous at room temperature, not flammable and does not generate corrosion.

According to standard 67/548/EEC, nitrogen is classified as a non-dangerous, colourless and odourless gas.

UNI EN 1089-3 standards provides for the identification of compressed-gas commercial bottles by a colour code system for ogives; for nitrogen, ogive colour is black RAL 9005.

For precharge, only use industrial dry nitrogen with minimum purity on volume accounting for 99.9 %, O₂ ≤ 50 Vpm and H₂O ≤ 30 Vpm.

It is important to use nitrogen bottles equipped with pressure regulator. Use DP-type precharge appliance to check and recharge nitrogen pressure to the value calculated and/or to adjust it, if necessary.

If precharge pressure is lower than value specified, connect the blowing pipe to the appliance on one side and, on the other side, connect with nitrogen bottle or pressure reducer; slowly inflow nitrogen into accumulator until the pressure reached is slightly higher than pressure specified (+ 10 ÷ 15 %).

Close the bottle and remove the connection pipe from appliance; wait until the gas temperature becomes stable (2 hours) and calibrate pressure by releasing gas in excess.

(Anyway, comply with instructions on control and precharge appliance manual).

Ensure that gas valve does not leak by using water and soap, if necessary.

Hydraulic pressurization

- ensure that precharge pressure is suitable for application.
- ensure that hydraulic pressure never exceeds max. value allowed as shown on accumulator body

Maintenance and routine checks

- routinely check gas precharge pressure (for the types equipped with gas valve): after commissioning, check after 2-3 week operation; if no leaks are detected, repeat operation after 3 months; if pressure remains stable, with equivalent temperature, repeat checks yearly. For heavy-duty applications, check precharge every 6 months.
- routinely perform (yearly) a visual check on accumulator to identify any initial sign of deterioration, such as corrosion, etc.
- comply with standard requirements in force concerning routine operating check of appliances depending on the country where accumulator is installed.

Disassembly

When the accumulator needs to be disassembled from the plant, because of malfunction, scheduled check or retest, before removing, fully discharge liquid pressure.

- strongly fasten the lower part in a vice
- remove precharge valve (after fully discharging nitrogen, for types not equipped with gas valve)

Repair

It can only provides for the replacement of precharge valve, if the type is equipped with it.

For operating and safety reasons, it is recommended to use original spare parts only.

Reassembly

After an accurate cleaning, reassemble the precharge valve by 30 0/+5 Nm tightening torque.

Precharge

- fasten DP precharge appliance on gas valve
- connect appliance to nitrogen bottle or pressure reducer by blowing pipe
- slowly inflow nitrogen into accumulator until the pressure reached is slightly higher than value specified (+ 10 ÷ 15 %).
- close the bottle and remove the connection pipe from appliance
- wait until the gas temperature is stable (2 hours)
- calibrate pressure by discharging gas in excess (Anyway, comply with instructions on control and precharge appliance manual).

Accumulator demolition and recycle

Before demolishing or recycling accumulator, precharge pressure must always be fully discharged and gas valve needs to be removed.

If necessary, decontaminate depending on fluid used before demolition.

Environmental information

Nitrogen does not generate any environmental damage; dispose of in atmosphere in a well-ventilated environment.

Maintenance free welded membrane accumulators/dampeners

Construction: carbon steel body Capacity: 0,05÷4 litres Pressure: up to 350 bar

ACC WA 10/14 EN



For SAIP in Italy or worldwide,
go to www.saip.it or
contact SAIP Sale Service
number +39 02.57603913

SAIP Srl
Via Lambro 25 - 20090 Opera (MI) - Italy
Ph. +39 02.57603913/+39 02.57606230
Fax +39 02 57604752
saip@saip.it - www.saip.it

