

## GERSZ..M..WD - Gerades Einschraub-Rückschlagventil

Metr. Einschraubzapfen mit WD (ISO 9974) / 24°-Anschluss

## GERSZ..M..WD - Straight male non-return valve

thread: metric parallel with captive seal (ISO 9974) / 24° cone end

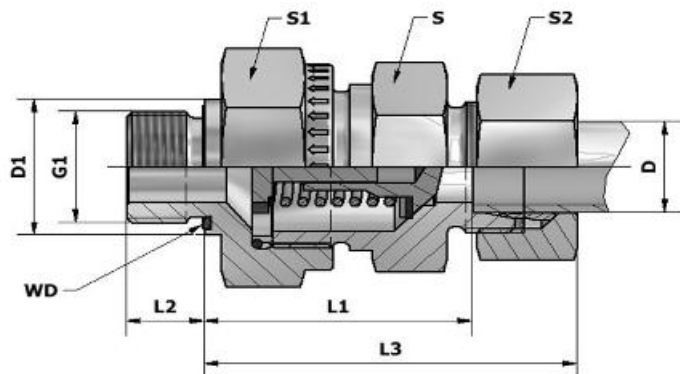

Öffnungsdruck serienmäßig 1 bar / cracking pressure standard 1 bar

Reihe series	D	G1	L1	L2	L3	S	S1	S2	Gewicht weight kg/100	Sach-Nr. comp.no.	Artikel-Nr. part.no.
L PN 400	6	M10x1	26,5	8,0	41,0	17	17	14	5,45	50970/21	GERSZ6M10ZLWDPc3d
	8	M12x1,5	28,5	12,0	43,0	19	19	17	7,50	50971/21	GERSZ8M12ZLWDPc3d
	10	M14x1,5	38,5	12,0	53,0	22	24	19	12,65	50972/21	GERSZ10M14ZLWDPc3d
	12	M16x1,5	40,5	12,0	55,0	27	30	22	19,70	50973/21	GERSZ12M16ZLWDPc3d
	15	M18x1,5	42,5	14,0	58,0	27	32	27	21,80	50974/21	GERSZ15M18ZLWDPc3d
	18	M22x1,5	48,0	14,0	64,0	36	41	32	34,35	50975/21	GERSZ18M22ZLWDPc3d
PN 250	22	M26x1,5	56,0	16,0	72,0	41	46	36	54,50	50976/21	GERSZ22M26ZLWDPc3d
	28	M33x2	64,0	18,0	81,0	50	55	41	81,35	50977/21	GERSZ28M33ZLWDPc3d
	35	M42x2	70,0	20,0	92,0	60	65	50	122,00	50978/21	GERSZ35M42ZLWDPc3d
	42	M48x2	70,5	22,0	93,0	65	70	60	183,20	50979/21	GERSZ42M48ZLWDPc3d
S PN 420	6	M12x1,5	31,5	12,0	46,0	19	19	17	8,65	50980/21	GERSZ6M12ZSWDPc3d
	8	M14x1,5	31,5	12,0	46,0	19	19	19	9,40	50981/21	GERSZ8M14ZSWDPc3d
	10	M16x1,5	38,0	12,0	54,0	22	24	22	15,55	50982/21	GERSZ10M16ZSWDPc3d
	12	M18x1,5	41,0	12,0	57,0	24	27	24	19,50	50983/21	GERSZ12M18ZSWDPc3d
	16	M22x1,5	46,0	14,0	64,0	32	36	30	34,30	50984/21	GERSZ16M22ZSWDPc3d
	20	M27x2	50,0	16,0	72,0	41	50	36	59,05	50985/21	GERSZ20M27ZSWDPc3d
PN 250	25	M33x2	54,5	18,0	79,0	46	55	46	85,25	50986/21	GERSZ25M33ZSWDPc3d
	30	M42x2	64,0	20,0	91,0	60	60	50	140,95	50987/21	GERSZ30M42ZSWDPc3d
	38	M48x2	71,5	22,0	102,0	65	70	60	199,80	50988/21	GERSZ38M48ZSWDPc3d

Ansprechdruck serienmäßig 1 bar.

Auf Wunsch auch in 0,2 / 0,5 / 2 / 3 / 4 / 5 und 6 bar lieferbar.

Toleranz des Ansprechdrucks  $\pm 20\%$

Standard cracking pressure 1 bar.

Also with 0,2 / 0,5 / 2 / 3 / 4 / 5 and 6 bar available.

Cracking pressure tolerance  $\pm 20\%$

Serienmäßig mit Dichtung aus NBR / Auf Wunsch mit FKM lieferbar

Supplied with fitted NBR sealing / FKM on request