



"M4" AVVOLGITUBO A 4 VIE
CON DOPPIA MOLLA ESTERNA

"M4" ENROULERS HYDRAULIQUE A 4 TUYAUX
AVEC 2 RESSORTS EXT. INDEPEND.

"M4" 4 PORT HOSE-REEL
WITH 2 INDEPENDENT OUTER SPRINGS

"M4" VIERFACH - SCHLAUCHROLLE
MIT 2 UNABHÄNGIGEN ÄUßEREN FEDERN

M4



SINISTRO
LEFT



141.1

MAX
40 l/min

W. P. 300 bar
Option 400 bar

MAX HOSE SPEED
30 m/min

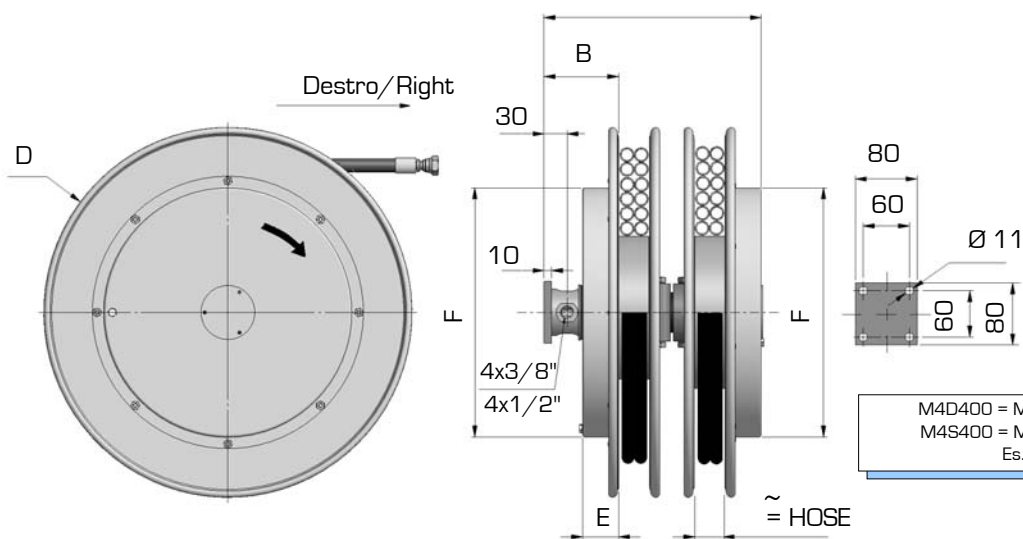
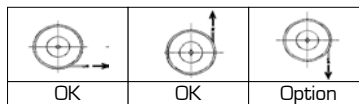

M4D400 = MODELLO DESTRO / RIGHT MODEL
M4S400 = MODELLO SINISTRO / LEFT MODEL
Es. ORD: M4D 600.10.R7

Modello destro Right model	A	B	D	E	F	Con tubo - with hose R7 -R8 -B1 - B2		
						Ø	Lungh.totale	Lungh.utile
							Total length	Usable length
mm						m	m	
M4D370.06.XX	282	97	370	47	272	1/4"	6,0	5,7
M4D370.08.XX						5/16"	5,3	5,0
M4D370.10.XX						3/8"	4,5	4,2
M4D370.12.XX						1/2"	3,5	3,2
M4D400.06.XX	282	97	400	47	272	1/4"	7,3	7,0
M4D400.08.XX						5/16"	6,5	6,2
M4D400.10.XX						3/8"	5,6	5,3
M4D400.12.XX						1/2"	4,5	4,2
M4D420.06.XX	282	97	420	47	322	1/4"	8,6	8,1
M4D420.08.XX						5/16"	8,0	7,5
M4D420.10.XX						3/8"	6,7	6,2
M4D420.12.XX						1/2"	4,7	4,2
M4D470.06.XX	282	97	478	47	322	1/4"	11,5	11,0
M4D470.08.XX						5/16"	10,0	9,5
M4D470.10.XX						3/8"	9,5	9,0
M4D470.12.XX						1/2"	7,5	7,0
M4D520.06.XX	282	97	520	47	422	1/4"	14,5	14,0
M4D520.08.XX						5/16"	12,5	12,0
M4D520.10.XX						3/8"	11,2	10,7
M4D520.12.XX						1/2"	9,0	8,5
M4D570.06.XX	282	97	570	47	422	1/4"	17,5	17,0
M4D570.08.XX						5/16"	15,5	15,0
M4D570.10.XX						3/8"	13,5	13,0
M4D570.12.XX						1/2"	10,7	10,2
M4D600.06.XX	282	97	620	47	422	1/4"	21,0	20,5
M4D600.08.XX						5/16"	17,0	16,5
M4D600.10.XX						3/8"	16,0	15,5
M4D600.12.XX						1/2"	12,5	12,0
M4D650.06.XX	282	97	650	47	422	1/4"	22,5	22,0
M4D650.08.XX						5/16"	19,5	19,0
M4D650.10.XX						3/8"	17,5	17,0
M4D650.12.XX						1/2"	14,5	14,0
M4D700.06.XX	282	97	720	47	532	1/4"	27,0	26,5
M4D700.08.XX						5/16"	22,0	21,5
M4D700.10.XX						3/8"	20,0	19,5
M4D700.12.XX						1/2"	16,0	15,5